

# Built on Tradition



# Highland Tank®



## Premium ASME Pressure Vessels from the Industry Leader

### Standard Features

- Manufactured to ASME Code
  - Standard design pressures are 125 and 150 psi. (Other pressure ratings are available.)
- Inlet and Outlet connections (based on the compressor outlet connection dimensions)
- Bottom Drain Outlet
- Pressure Gauge connection
- Safety relief valve connection
- Inspection openings
- Exterior alkyd shop primer

## ASME Air Receiver Vessels

HT-1127

Air Receiver Tanks (ART) are used in compressed air systems to store the compressed air and to permit pressure to be equalized in the system.

ART are sized to best supplement the air compressor operation, typically one gallon of storage for each Actual Cubic Feet per Minute (ACFM), for the rated compressor output:

A more exact sizing method is:

$$V = Cr \times (Ci / Co)$$

V = Air Receiver Volume (ft<sup>3</sup>)

Cr = Compressor rating (ft<sup>3</sup> / min. free air)

Ci = Compressor Inlet Free Air (psia)

Co = Compressor Outlet Pressure (psia)

After calculating the air receiver capacity, inlet and outlet connections can be determined based on the size of the compressor outlet connection.

# Drawing & Details

**Vertical Air Receiver**

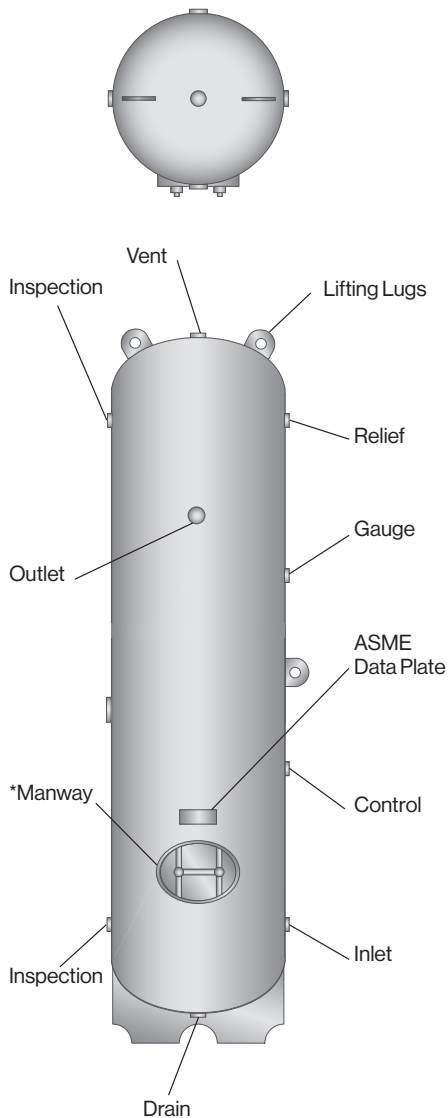

\* 12" X 16" minimum elliptical manway

**Options**

- Tank Support Systems:
- Horizontal - UL Saddles
- Vertical - Ring Bases, Angle Legs

All Highland Tank storage tank drawings are available for viewing or downloading in PDF or AutoCAD DXF format at [highlandtank.com](http://highlandtank.com)

**Horizontal Air Receiver**

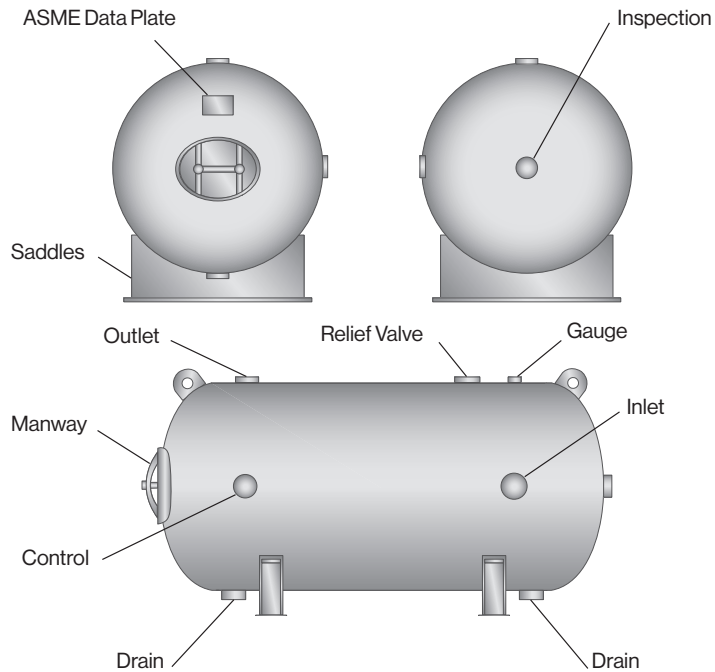

Airflow Capacity		Recommended Receiver Volume		
CFM	m <sup>3</sup> /hr.	ft. <sup>3</sup>	Gallons	m <sup>3</sup>
100	170	13	100	0.4
200	340	27	200	0.8
300	510	40	300	1.1
400	680	54	400	1.5
500	850	67	500	1.9
750	1,275	101	750	2.9
1,000	1,700	134	1,000	3.8
1,500	2,550	201	1,500	5.7
2,000	3,400	268	2,000	7.6
3,000	5,100	402	3,000	11.4
4,000	6,800	536	4,000	15.2
5,000	8,500	670	5,000	19.0
7,500	12,750	1,005	7,500	28.5
10,000	17,000	1,340	10,000	38.0



**Stoystown, PA**  
One Highland Rd.  
Stoystown, PA 15563  
(814) 893-5701

**Manheim, PA**  
4535 Elizabethtown Rd.  
Manheim, PA 17545  
(717) 664-0600

**Watervliet, NY**  
958 19th St.  
Watervliet, NY 12189  
(518) 273-0801

**Greensboro, NC**  
2700 Patterson St.  
Greensboro, NC 27407  
(336) 218-0801

**Friedens, PA**  
1510 Stoystown Rd.  
Friedens, PA 15541  
(814) 443-6800

**Clarkston, MI**  
4701 White Lake Rd.  
Clarkston, MI 48346  
(248) 625-8700

**Mancelona, MI**  
9517 Lake St.  
Mancelona, MI 49659  
(231) 587-8412