

Built on Tradition



Highland Tank®



Rectangular Aboveground OWS

HT-2027

Highland Tank Rectangular Oil/Water Separators are of the highest quality – constructed to American Petroleum Institute (API) and Underwriters' Laboratories (UL) specifications.

Highland Tank's separators are designed for the removal of free-floating oil, grease and settleable oily-coated solids from oil/water mixtures associated with many types of petroleum, industrial, commercial, military and municipal facilities.

Our high-efficiency oil/water separators are recommended for many industrial and commercial applications, such as:

- Airports & aircraft services
- Automobile dealers
- Electric utilities & power plants
- Environmental remediation
- Military & government facilities
- Petroleum marketing facilities
- Railroad yards
- Trucking and transportation
- Facility vehicle services



Rectangular oil/water separators can be installed aboveground to help industrial facilities comply with the EPA's spill and discharge regulations. Like our cylindrical underground units, these separators are equipped with our non-clogging Corella[®] coalescers that accelerate the separation process and greatly reduce the level of oil and oily-coated solids discharged into municipal storm or sanitary sewer.

Highland Tank oil/water separators set the standard for reliability. Our separators are highly efficient-treating wastewater under a wide range of conditions at fueling facilities, repair and maintenance shops, vehicle wash areas and many other industrial locations.

Easy to install, operate & maintain

UL-2215 LISTED

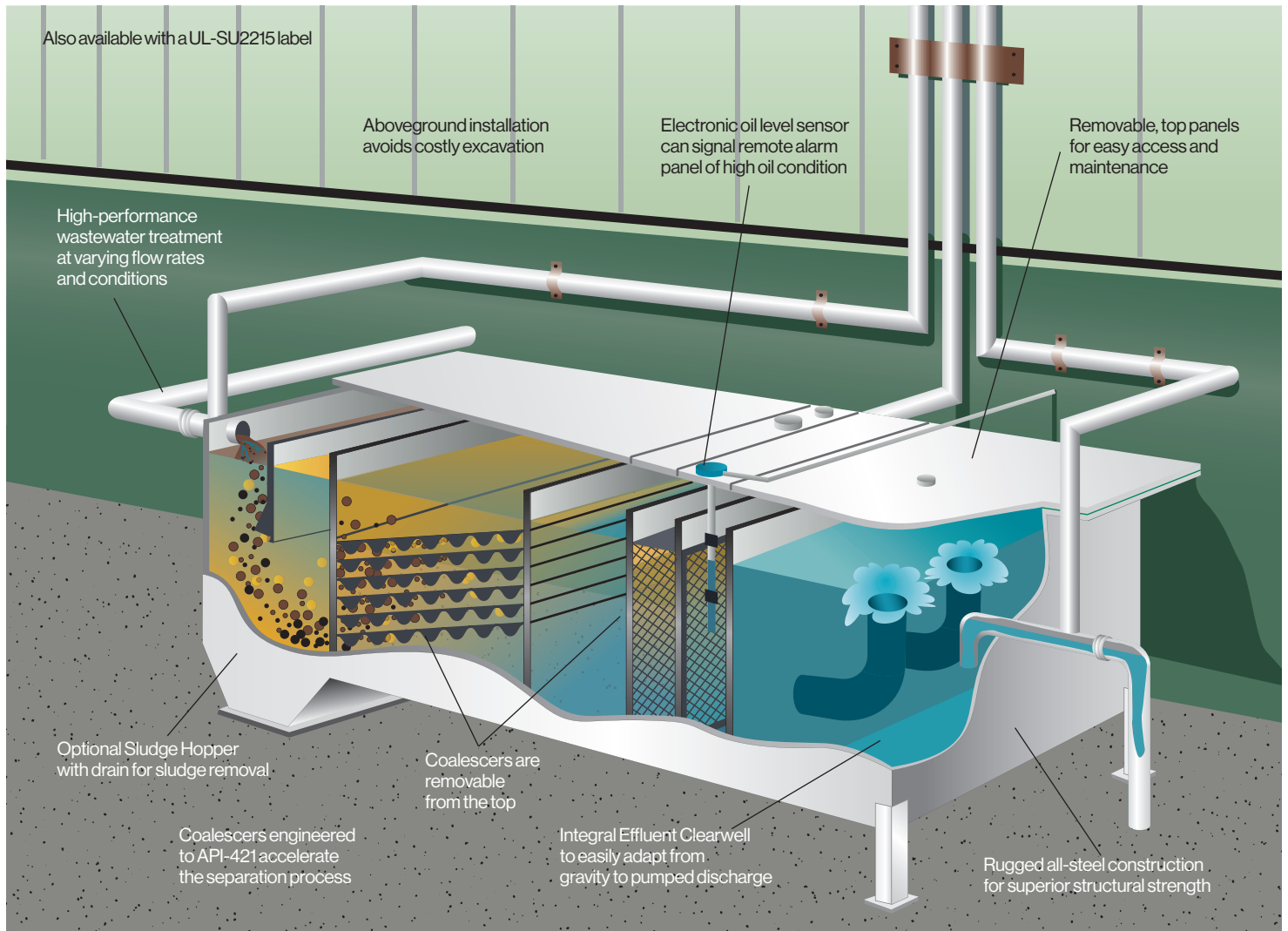

Optional Designs

Series - G Oil/Water Separators

Feature an integral sand interceptor compartment to permit sand and gravel to settle out before the wastewater enters the separation chamber.

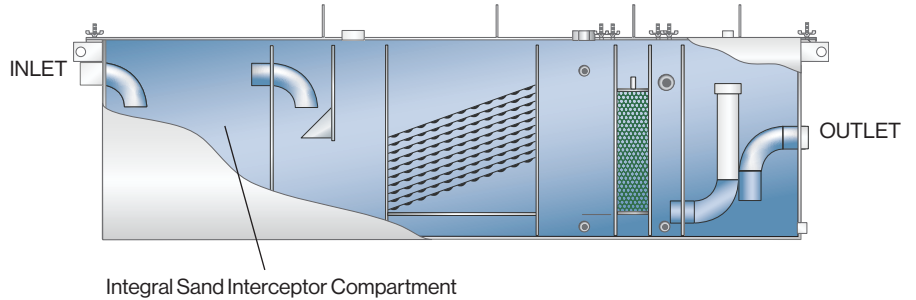

Series - J Oil/Water Separators

Feature an integral effluent pump-out compartment with level controls to operate a pump at prescribed levels. The pumped effluent can then be routed through Highland's Advanced Hydrocarbon Filtration System to further improve performance.

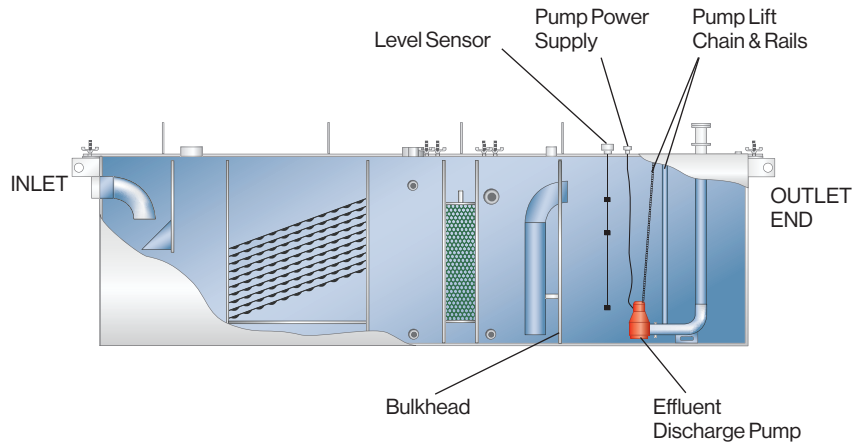

Series - S Oil/Water Separators

Feature an integral side product compartment for storing separated oil. The special side product compartment permits the removal of only the skimmed oil by pump-out. The effluent is discharged either by pump or gravity flow.

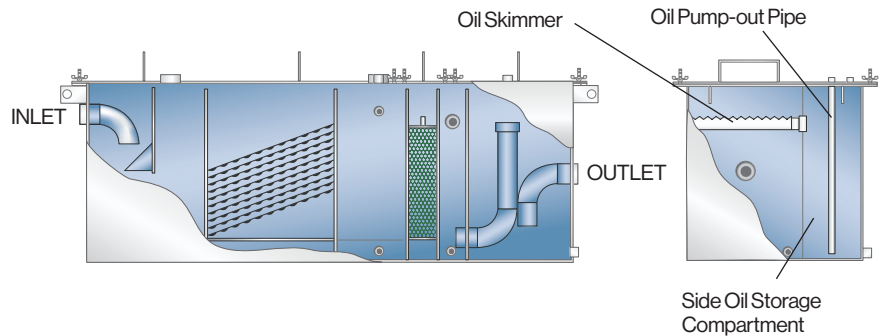

Series - TF Oil/Water Separators

Feature an integral "trickle filter" to remove dispersed and mechanically emulsified oils that may pass through the separator untreated. Water flows freely out of the separator to the diffusion pipe and passes through the oleophilic trickle filter media bags to remove any troublesome discharges. The media bags can be easily removed and replaced when necessary.

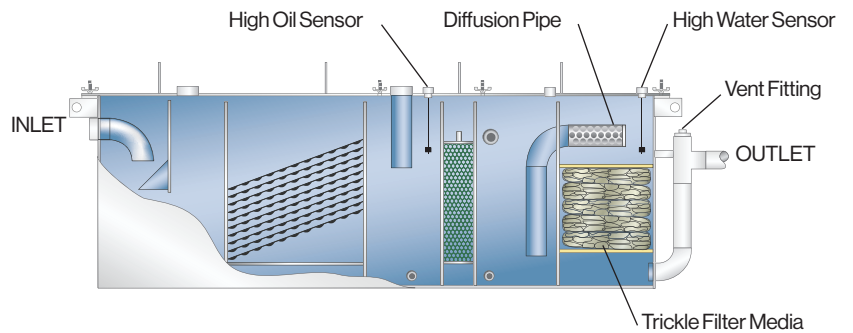

Highland Tank[®]

Drawing & Details

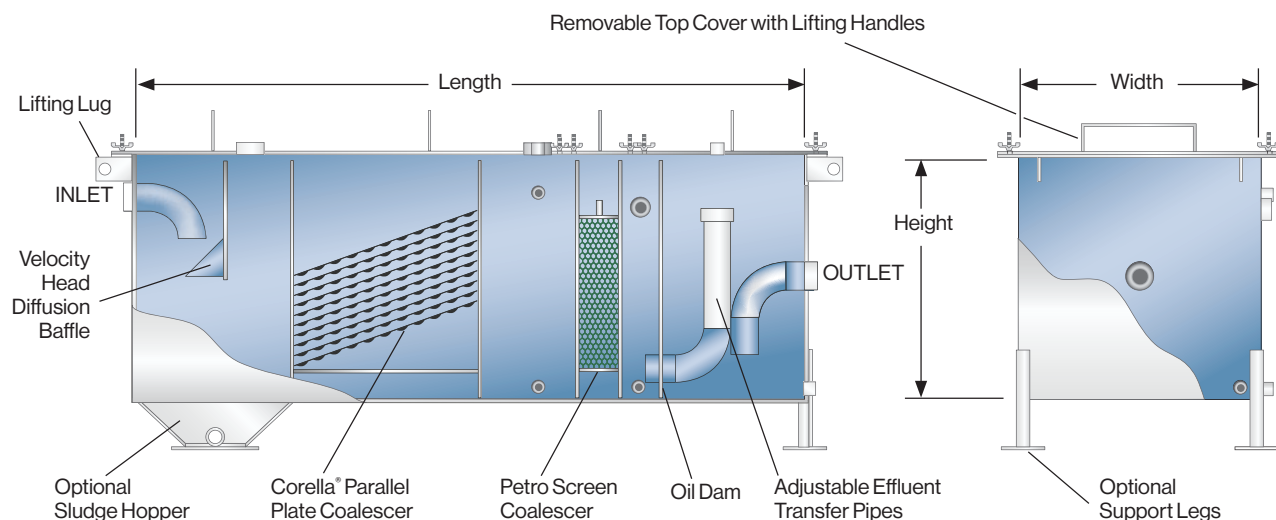

Model HT or HTC	Flow Rate Gal/Min	Total Volume Gallons	Recommended Oil Pump-Out Gallons	Nominal Dimensions			Inlet & Outlet Diameter
				Length	Width	Height	
100	5	100	20	5'-0"	1'-6"	3'-0"	1"
200	10	200	40	5'-0"	2'-0"	3'-0"	2"
300	25	300	60	7'-0"	2'-0"	3'-0"	3"
600	50	600	120	9'-0"	3'-0"	3'-0"	4"
900	75	900	180	10'-0"	3'-0"	4'-0"	6"
1,000	100	1,000	200	11'-0"	4'-0"	4'-0"	6"
2,000	200	2,000	400	12'-0"	5'-0"	5'-0"	8"
3,000	300	3,000	600	18'-0"	5'-0"	5'-0"	10"
4,000	400	4,000	800	18'-0"	6'-0"	5'-0"	10"
5,000	500	5,000	1,000	20'-0"	6'-0"	6'-0"	10"
6,000	600	6,000	1,200	19'-2"	7'-0"	6'-0"	10"
7,000	700	7,000	1,400	19'-2"	7'-0"	7'-0"	10"
8,000	800	8,000	1,600	19'-2"	8'-0"	7'-0"	10"
9,000	900	9,000	1,800	18'-10"	8'-0"	8'-0"	12"
10,000	1,000	10,000	2,000	20'-11"	8'-0"	8'-0"	12"
12,000	1,200	12,000	2,400	19'-10"	9'-0"	9'-0"	12"
15,000	1,500	15,000	3,000	24'-9"	9'-0"	9'-0"	14"
20,000	2,000	20,000	4,000	29'-9"	10'-0"	9'-0"	16"
25,000	2,500	25,000	5,000	33'-6"	10'-0"	10'-0"	18"
30,000	3,000	30,000	6,000	40'-10"	10'-0"	10'-0"	20"



Stoystown, PA
One Highland Rd.
Stoystown, PA 15563
(814) 893-5701

Manheim, PA
4535 Elizabethtown Rd.
Manheim, PA 17545
(717) 664-0600

Watervliet, NY
958 19th St.
Watervliet, NY 12189
(518) 273-0801

Greensboro, NC
2700 Patterson St.
Greensboro, NC 27407
(336) 218-0801

Friedens, PA
1510 Stoystown Rd.
Friedens, PA 15541
(814) 443-6800

Clarkston, MI
4701 White Lake Rd.
Clarkston, MI 48346
(248) 625-8700

Mancelona, MI
9517 Lake St.
Mancelona, MI 49659
(231) 587-8412