

# Fireguard<sup>®</sup> Thermally Protected Steel Storage Tanks

**Highland Tank**

*Cylindrical and Rectangular  
Aboveground Double-wall Tanks*

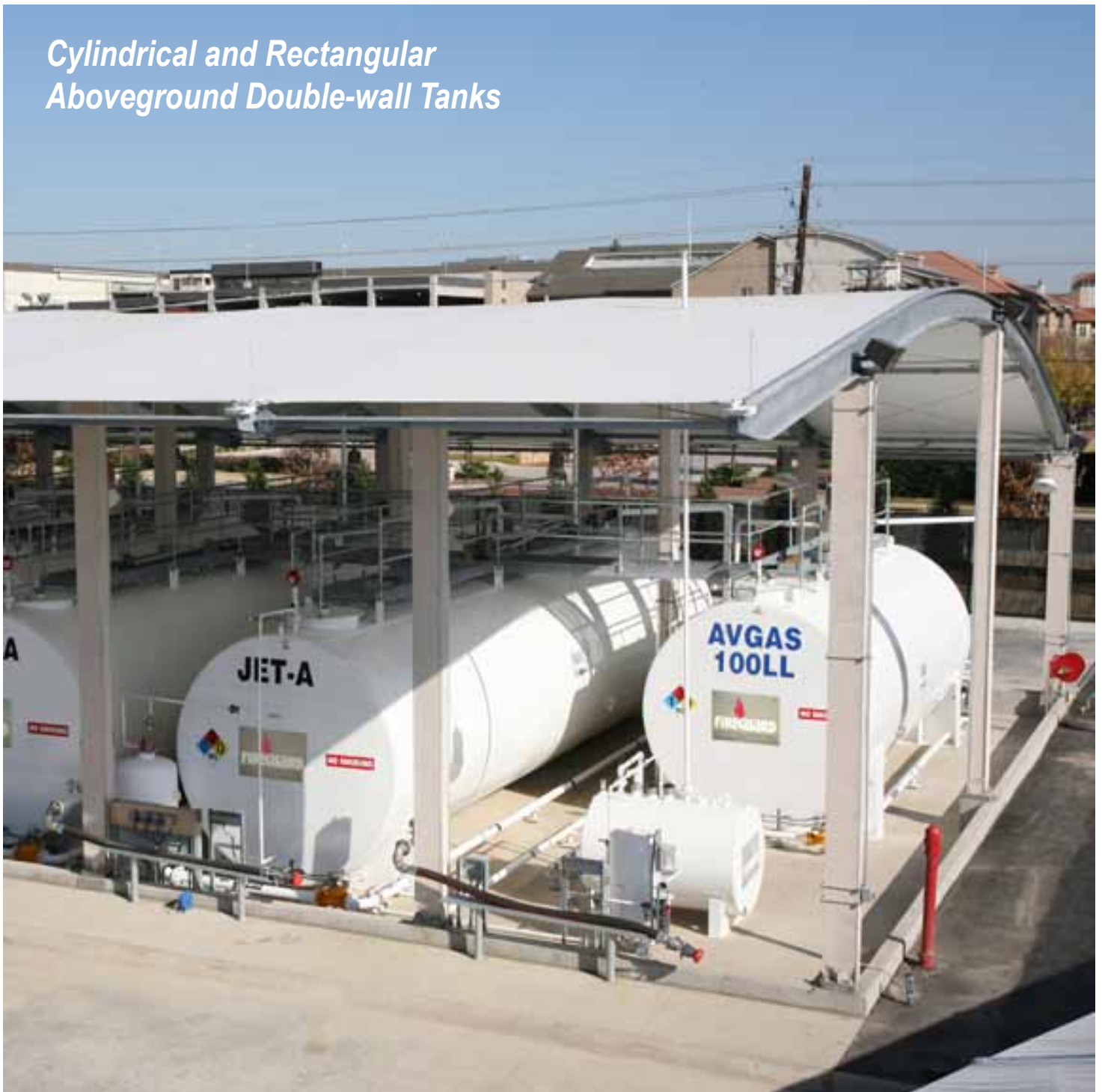

## The Fireguard® Tank with Pump and Alarm Systems

- **UL - 2085 Steel Secondary Containment Tank Passed**
  - 2-Hour Fire Test
  - Hose Stream Test
  - Impact Test
  - Ballistics Test
- **Lightweight**
- **Pressure Testable**
- **30-Year Warranty**

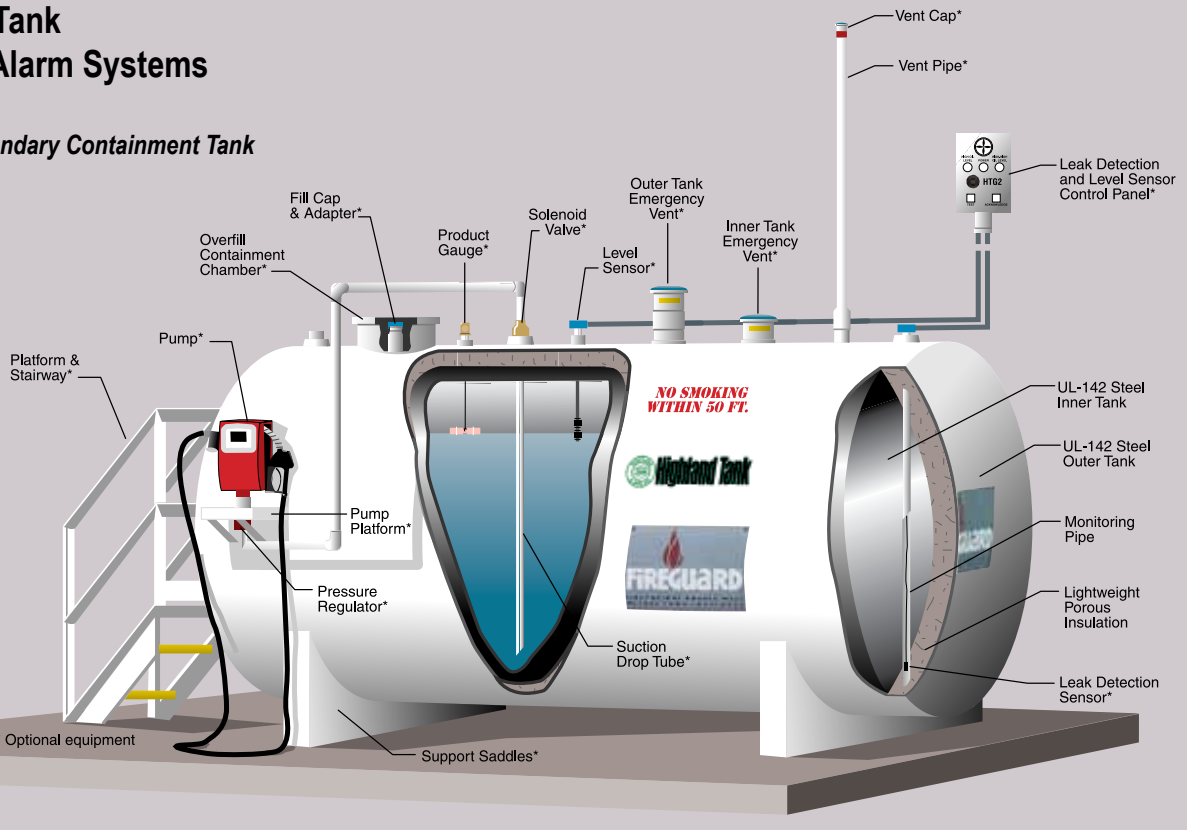

The Fireguard® is an attractive alternative for complying with the stringent underground tank regulations.

Fireguard® tanks are thermally protected, double-wall steel cylindrical or rectangular aboveground tanks. Fireguards® offer a smart alternative to the problem of safely storing motor fuels and other dangerous liquids aboveground. They are used where a fire-protected tank is needed because of setback limitations and/or regulatory insistence for storage of flammable and combustible liquids. These tanks are Underwriters' Laboratories UL-2085 labeled for Fire Protection, Impact Resistance, Ballistics Resistance and Secondary Containment.

Fireguard® tanks have been proven to meet the requirements outlined in UL-2085 including:

- Two-hour Full Scale fire Test
- Ballistics / Projectile Test
- Vehicle Impact test
- Hose Stream test
- 2-hour Pool Fire Test
- Interstitial Communication Test

Fireguard® is a licensed technology of the Steel Tank Institute under US Patent #s 5,695,089 & 5,809,650; Canadian Patent #s 2,141,357 & 2,263,657

Each tank is constructed with a minimum 3" interstice around the inner tank. The interstice is completely filled with a lightweight, monolithic material. This highly efficient insulation protects the inner tank in the unlikely event of a fire or extreme heat. The porous material allows fluid migration through the interstice to the monitoring point.

The thermal insulation material is a composition of perlite, cement, water and special ingredients carefully mixed to standardized proportions. The light weight of the completed tank unit eases relocation on projects that demand additional fire protection.

Unlike outdated concrete encased tanks, Fireguard's® steel outer wall protects the insulation, eliminating the problem of cracking and spalling concrete. And because of its unique construction, each Fireguard® is pressure-testable in the factory and at the site!

**Fireguard® Meets or Exceeds These Requirements:**

- UL-2085 Standard for Insulated Secondary Containment Aboveground Tanks
- Steel Tank Institute F941 Standard for Thermally Insulated Aboveground Storage Tanks
- UL-142
- 2000 International Fire Code
- NFPA 30 & 30A Codes
- CARB #G-70-162 (California Air Resources Board)
- 1993 Building Officials and Code Administrators (BOCA)
- National Fire Prevention Code
- Southern Building Code Congress International (SBCCI)
- Standard Fire Prevention Code



## Rectangular Design



| Nominal Capacity (Gallons) | Inner Tank |       |         | Outer Tank |       |         | Thickness |
|----------------------------|------------|-------|---------|------------|-------|---------|-----------|
|                            | W          | H     | L       | W          | AOH*  | L       |           |
| 500                        | 3'-0"      | 3'-0" | 7'-6"   | 4'-0"      | 4'-6" | 8'-6"   | 10 ga.    |
| 1,000                      | 4'-8"      | 3'-0" | 9'-8"   | 5'-2"      | 4'-1" | 10'-3"  | 7 ga.     |
| 2,000                      | 6'-4"      | 4'-0" | 10'-8"  | 6'-10"     | 5'-1" | 11'-4"  | 1/4"      |
| 3,000                      | 5'-5"      | 5'-5" | 13'-8"  | 5'-11"     | 6'-5" | 14'-3"  | 1/4"      |
| 4,000                      | 5'-5"      | 5'-5" | 18'-2"  | 5'-11"     | 6'-5" | 18'-9"  | 1/4"      |
| 5,000                      | 5'-5"      | 5'-5" | 22'-9"  | 5'-11"     | 6'-5" | 23'-4"  | 1/4"      |
| 6,000                      | 10'-10"    | 5'-5" | 13'-8"  | 11'-4"     | 6'-5" | 14'-3"  | 1/4"      |
| 6,000                      | 5'-5"      | 5'-5" | 27'-4"  | 5'-11"     | 6'-5" | 27'-11" | 1/4"      |
| 8,000                      | 10'-10"    | 5'-5" | 18'-2"  | 11'-4"     | 6'-5" | 18'-9"  | 1/4"      |
| 10,000                     | 10'-10"    | 5'-5" | 22'-10" | 11'-4"     | 6'-5" | 23'-5"  | 1/4"      |
| 12,000                     | 10'-10"    | 5'-5" | 27'-4"  | 11'-4"     | 6'-5" | 27'-11" | 1/4"      |

## Cylindrical Design



| Nominal Capacity Gallons | Inner Tank |        | Outer Tank |        |         | Thickness |
|--------------------------|------------|--------|------------|--------|---------|-----------|
|                          | Dia.       | L      | Dia.       | AOH*   | L       |           |
| 300                      | 3'-2"      | 5'-0"  | 4'-2"      | 5'-0"  | 6'-0"   | 10 ga.    |
| 500                      | 4'-0"      | 5'-5"  | 4'-6"      | 5'-4"  | 6'-0"   | 10 ga.    |
| 1,000                    | 4'-0"      | 10'-9" | 4'-6"      | 5'-4"  | 11'-4"  | 10 ga.    |
| 1,000                    | 5'-4"      | 6'-0"  | 5'-10"     | 6'-8"  | 6'-7"   | 7 ga.     |
| 2,000                    | 5'-4"      | 12'-0" | 5'-10"     | 6'-8"  | 12'-7"  | 7 ga.     |
| 3,000                    | 5'-4"      | 18'-0" | 5'-10"     | 6'-8"  | 18'-7"  | 7 ga.     |
| 4,000                    | 5'-4"      | 24'-0" | 5'-10"     | 6'-8"  | 24'-7"  | 7 ga.     |
| 4,000                    | 8'-0"      | 10'-8" | 8'-6"      | 9'-4"  | 11'-3"  | 1/4"      |
| 5,000                    | 8'-0"      | 13'-4" | 8'-6"      | 9'-4"  | 13'-11" | 1/4"      |
| 6,000                    | 8'-0"      | 16'-0" | 8'-6"      | 9'-4"  | 16'-7"  | 1/4"      |
| 8,000                    | 8'-0"      | 21'-4" | 8'-6"      | 9'-4"  | 21'-11" | 1/4"      |
| 10,000                   | 8'-0"      | 26'-8" | 8'-6"      | 9'-4"  | 27'-3"  | 1/4"      |
| 12,000                   | 8'-0"      | 32'-0" | 8'-6"      | 9'-4"  | 32'-7"  | 1/4"      |
| 15,000                   | 10'-0"     | 25'-6" | 10'-6"     | 11'-4" | 27'-1"  | 1/4"      |
| 20,000                   | 10'-0"     | 34'-0" | 10'-6"     | 11'-4" | 34'-7"  | 1/4"      |
| 25,000                   | 10'-0"     | 42'-7" | 10'-6"     | 11'-4" | 43'-2"  | 1/4"      |
| 30,000                   | 10'-0"     | 51'-2" | 10'-6"     | 11'-4" | 51'-9"  | 1/4"      |
| 40,000                   | 11'-6"     | 51'-6" | 12'-0"     | 13'-0" | 52'-1"  | 3/8"      |

\*AOH - Approximate Overall Height; AOL - Approximate Overall Length

Highland offers a wide range of accessories and options to configure your tank for a specific application including: Diesel and Gasoline Dispensing, Emergency Diesel-Electric Generator Systems, and Waste Oil Recovery Systems. Compartmented designs, stairs, platforms, and catwalks, electronic leak and level sensing systems, special internal and external coatings, and custom designs are available.

## Weigh the Fireguard® Advantages

- Carries UL-2085 listing as Protected Insulated Secondary Containment for Flammable Liquids
- 2-hour fire rating
- Lightweight — insulation 75% lighter than concrete — costing less to ship and install, and/or relocate
- Reduces tank setback and separation distance requirements by up to 50%
- Pressure testable at site per NFPA 30 1996
- Steel outer wall protects insulation
- Available in rectangular or cylindrical design
- Wide tank capacity range of 300 to 30,000 gallons
- Available with bulkheads for split tanks
- Subject to three-tier Quality Assurance Program for licensed manufacturers
- STI 30-year limited warranty on all tanks

## General Arrangement

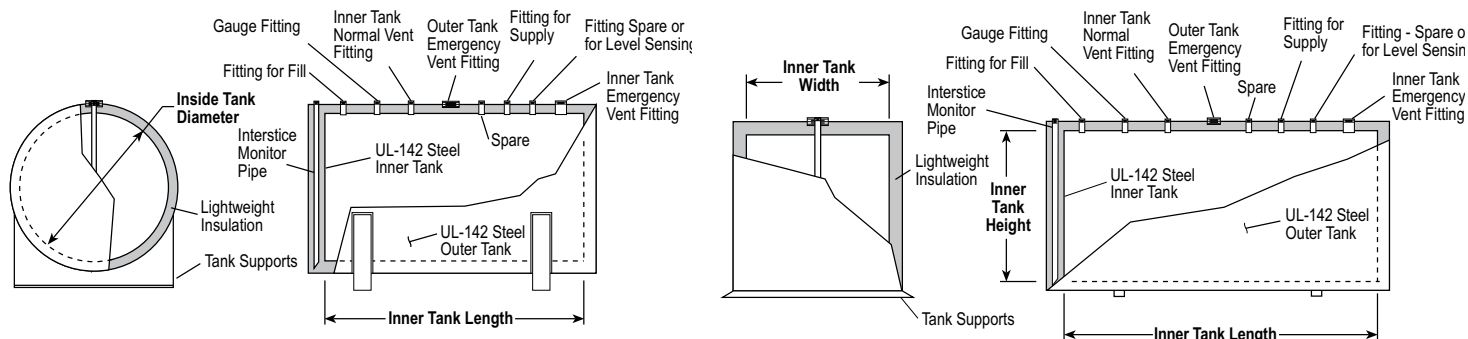

## Recommended Guide Specification

### General

Provide and install \_\_\_\_\_ Highland Tank UL-2085 Fireguard® Thermally Insulated, Double-Wall Steel Aboveground Storage Tank. Tank storage volume shall be \_\_\_\_\_. Tank shall be \_\_\_\_\_ wide x \_\_\_\_\_ high x \_\_\_\_\_ long. Approximate weight shall be \_\_\_\_\_ (lb.).

The tank shall be designed for aboveground storage of flammable and combustible liquids at atmospheric pressure. Tank shall include integral steel secondary containment and thermal insulation that provides a minimum two-hour fire rating.

Each tank shall be delivered as a complete UL-listed assembly with two factory supplied, welded-on saddles. Size and location of saddles shall be as required by the manufacturer. Saddles to be set level on a solid foundation.

Tank shall be designed for possible relocation at a future date (heavy, concrete-encased designs will **NOT** be permitted).

Tank shall comply with National Fire Protection Association NFPA 30 Flammable and Combustible Liquids Code. The tank's secondary containment must be tested for tightness in the factory and in the field before commissioning. Tank shall be supplied with emergency venting for the primary and the secondary containment tanks (emergency venting by "form of construction" will **NOT** be permitted).

Inner and Outer Tank shall be manufactured in accordance with UL 142 Standard for Steel Aboveground Tanks for Flammable and Combustible Liquids and labeled for Underwriters Laboratories UL 2085 Standard for Insulated Secondary Containment Aboveground Tank for Flammable Liquids. The tank design shall be UL 2085 listed as both "Protected" and "Fire-Resistant" and tested for Ballistics, Impact, Hose Stream, and Pool Fire UL-2085 performance standards compliance.

Tank shall be manufactured and labeled in strict accordance with Steel Tank Institute (STI) Fireguard® Thermally Insulated, Double Wall Steel Aboveground Storage Tank standards as applied by a licensee of the STI. Tank shall be subject to the STI's Quality Assurance program and shall be backed by the STI 30 year limited warranty.

The tank system shall also meet or exceed the requirements of:

- National Fire Protection Association NFPA 30A Automobile And Marine Service Station Code.
- 2000 International Fire Code (IFC)
- California Air Resources Board (CARB) testing requirements for air emissions.
- Southern Building Code Congress International (SBCCI) Standard Fire Prevention Code.
- 1993 Building Officials and Code Administrators (BOCA) National Fire Prevention Code.

### Construction

Tank shall be fabricated per UL-142 and UL-2085 Codes, of mild carbon steel with shell seams of continuous lap weld construction.

Tank shall be of double wall construction and provide complete secondary containment of the primary storage tank's contents by an impervious steel outer wall.

A minimum of 3" of porous, lightweight monolithic thermal insulation material shall be installed at the factory within the interstitial space between the inner and outer walls.

Thermal insulating material:

- shall be in accordance with American Society of Testing Materials (ASTM) Standards C-332 and C-495.
- shall allow liquid to migrate through it to the monitoring point.
- shall not be exposed to weathering and shall be protected by the steel secondary containment outer wall (an exterior concrete wall or vault exposed to the elements will **NOT** be permitted).

Lifting lugs shall be provided at balancing points to facilitate handling and installation.

Exterior Protective Coating:

- Surface Preparation: Grit blast - SSPC-SP-6 Commercial Blast.
- Finish: White finish paint system 3-5 DFT on the shell and heads.

Threaded fittings with thread protectors shall be supplied as follows (all fittings must be located on tank top per UL):

- One (1) 2" - Interstitial Monitoring.
- One (1) 2" - Normal Vent, Primary Tank.
- One (1) 4", 6", or 8" - Emergency Vent, Primary Tank.

- One (1) 4", 6", or 8" - Emergency Vent, Secondary Tank.
- One (1) 4", 6" - Product Fill.
- One (1) 2" - Product Pump or Supply.
- One (1) 2" - Product Return or Auxiliary.
- One (1) 2" - Liquid Level Gauge.
- One (1) 4" - Stage 1 Vapor Recovery, Electronic Level Stage 1 Gauge, or Auxiliary.
- One (1) 18" Manway (min.) for tanks greater than 4,000 gallons.
- Additional fittings available upon request.

### Optional Equipment

- Bulkhead(s) for Split Tank.
- Manway(s) \_\_\_\_\_".
- Pump Mount(s) for Top Mount, Side Mount, or for Free Standing Pumps and Dispensers on Standard or Split Tanks.
- "Spill-mate" for remote fill.
- External Ladder.
- External Ladder Platform.
- Walkway(s) with Handrails.
- Stairs and Platforms with Handrails.
- Internal Ladder(s).
- Internal Coating with Interior Weld (500 gal. minimum).
- Monitoring Systems.
- Fuel Management System.
- Electronic Overfill Detection Sensors and Alarm Panels.
- Equipment Packages are available for:
  - Gasoline Dispensing
  - Diesel Dispensing
  - Emergency Generators
  - Waste Oil Recovery
  - Aviation Fuel (Avgas, Jet-A, or Jet A-1)
- OP™ Tank - Integral Overfill Protection construction

### Execution

Tank shall be installed on a reinforced concrete base constructed by the owner. Installation and testing shall be in strict accordance with Steel Tank Institute Installation and Testing Instructions for Thermally Insulated, Lightweight, Double Wall Fireguard® Aboveground Storage Tanks.

Approved Manufacturer: Tank shall be manufactured by Highland Tank; Stoystown, PA; Manheim, PA; Watervliet, NY; Lebanon, PA; Greensboro, NC; or Friedens, PA.



Please visit us at [www.highlandtank.com](http://www.highlandtank.com) • Email us at [tanks@highlandtank.com](mailto:tanks@highlandtank.com)

One Highland Road  
Stoystown, PA 15563  
814-893-5701  
FAX 893-6126

4535 Elizabethtown Road  
Manheim, PA 17545  
717-664-0600  
FAX 664-0617

958 19th Street  
Watervliet, NY 12189  
518-273-0801  
FAX 273-1365

2700 Patterson Street  
Greensboro, NC 27407  
336-218-0801  
FAX 218-1292

2225 Chestnut Street  
Lebanon, PA 17042  
717-664-0602  
FAX 664-0631

1510 Stoystown Road  
Friedens, PA 15541  
814-443-6800  
FAX 444-8662