

Highland Hopper Series Vertical Storage Tanks

Economical Secondary Containment



Highland Hopper Series

Highland Hoppers are state-of-the-art technology for low profile, secondarily contained, aboveground storage. They are suitable for the storage of all types of liquid fuels, new and used oils, waste solvents and antifreeze. Available in nine convenient capacities, there's a Highland Hopper for your requirements. All Highland Hoppers are designed and built to UL

142 specifications. Each Hopper consists of an inner tank, placed in the second tub-like steel container, which provides a minimum of 110% secondary containment. The unique, extended top design prevents rain, snow and debris from collecting in the secondary containment. Elevation supports and a 2" interstitial monitoring pipe are included on all models.

Rated for storage of flammable or combustible liquids, the Petro-Hopper is suitable for storing gasoline, kerosene, or diesel fuel. Haz-Hoppers are specifically engineered for the storage of waste oil or waste thinner. Highland's Fuel-Hopper is designed for storing flammable and combustible liquids such as heating oil or generator fuel.

Nominal Capacity (Gallons)	Tank		Overall		Thickness
	Diameter	Depth	Diameter	Height	
120	30"	40"	36"	46"	12 ga.
185	38"	40"	44"	47"	12 ga.
285	46"	40"	52"	51"	12 ga.
500	62"	40"	68"	53"	12 ga.
1,000	84"	42"	92"	54"	7 ga.
1,500	96"	48"	108"	60"	7 ga.
2,000	108"	51"	120"	63"	7 ga.
2,500	108"	62"	120"	75"	7 ga.
3,000	108"	76"	120"	91"	7 ga.

Standard accessories vary on Hopper Series Tanks. See back for details. A limited number of options are available such as pump mounts and red, blue, green, yellow or white finish paint.

All Highland Hoppers include:

- 2" x 8' Vent pipe with mushroom (normal) vent
- 4" or 6" Emergency vent
- Fittings for necessary connections
- 2" Interstitial monitoring pipe
- Elevation Supports

Petro-Hopper

Designed for storage of flammable or combustible liquids (kerosene, gasoline, diesel).

Includes:

- 4" or 6" Emergency vent
- 2" Mushroom vent
- Gauge
- Spill container with lockable lid
- 2" Fill pipe and cap
- 2" dia. x 8' L Vent pipe

Painted red primer. Optional Finish Paint: red, blue, green, yellow, or white at additional cost.

Recommended Guide Specification

Furnish () qty. _____ gallon PETRO-HOPPERS for flammable and combustible liquid storage. Tank(s) to include: 4" or 6" emergency vent, gauge, spill container with lockable lid, 2" fill cap, and 2" dia. x 8'0" L vent pipe with mushroom vent. Tank(s) will bear UL 142 Label for Closed Top Dike Aboveground Tank for Flammable Liquids. Tank(s) and containment to be painted _____. Tank(s) to be manufactured by Highland Tank & Mfg. Co., Manheim, PA; Stoystown, PA; Greensboro, NC; or Watervliet, NY.

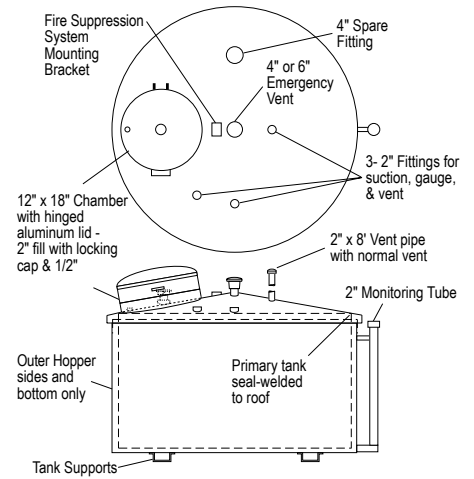

Haz-Hopper

Designed for storage of waste oil or waste thinner. Includes:

- 4" or 6" Emergency vent
- 2" Mushroom vent
- 10" Quick opening fill
- 12" x 16" Access opening
- 2" Quick connect
- 2" dia. x 8' L Vent pipe

Painted red primer. Optional Finish Paint: Red for Waste Solvent or Blue for Waste Oil at additional cost.

Recommended Guide Specification

Furnish () qty. _____ gallon HAZ-HOPPERS for waste _____ holding tank. Tank(s) to include: 4" or 6" emergency vent, 10" quick-opening fill, 12" x 16" clean-out port, 2" quick connect, and 2" dia. x 8'0" L vent pipe with mushroom vent. Tank(s) will bear UL 142 Label for Closed Top Dike Aboveground Tank for Flammable Liquids. Tank(s) and containment to be painted _____. Tank(s) to be manufactured by Highland Tank & Mfg. Co., Manheim, PA; Stoystown, PA; Greensboro, NC; or Watervliet, NY.

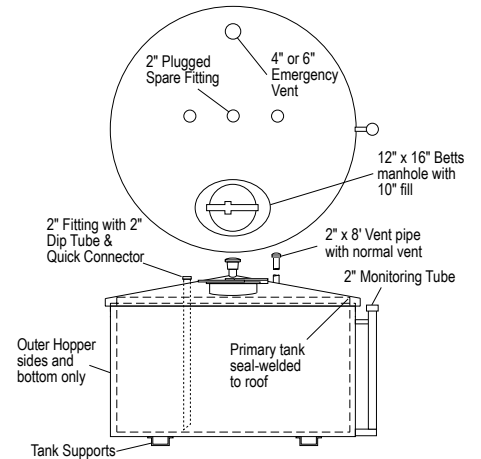

Fuel-Hopper

Designed for storage of flammable and combustible liquids (heating oil). Includes:

- 4" or 6" Emergency vent
- 2" Mushroom vent
- 2" Fill pipe and cap
- 2" x 8' L Vent pipe

Painted red primer. Optional Finish Paint: red, blue, green, or white at additional cost.

Recommended Guide Specification

Furnish () qty. _____ gallon FUEL-HOPPERS for flammable and combustible liquid storage. Tank(s) to include: 4" or 6" emergency vent and 2" fill cap. Tank(s) will bear UL 142 Label for Closed Top Dike Aboveground Tank for Flammable Liquids. Tank(s) and containment to be painted _____. Tank(s) to be manufactured by Highland Tank & Mfg. Co., Manheim, PA; Stoystown, PA; Greensboro, NC; or Watervliet, NY.

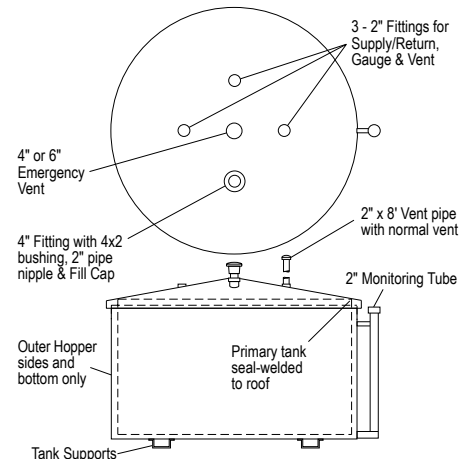

Please visit us at www.highlandtank.com

One Highland Road
Stoystown, PA 15563
814-893-5701
FAX 893-6126

4535 Elizabethtown Road
Manheim, PA 17545
717-664-0600
FAX 664-0617

958 19th Street
Watervliet, NY 12189
518-273-0801
FAX 273-1365

2700 Patterson Street
Greensboro, NC 27407
336-218-0801
FAX 218-1292

2225 Chestnut Street
Lebanon, PA 17042
717-664-0602
FAX 664-0631

1510 Stoystown Road
Friedens, PA 15541
814-443-6800
FAX 444-8662