



Highland Tank

The Oil/Water Separator

Users' Manual

Installation

Venting Guidelines

Start-up

Operation

Maintenance

Trouble Shooting

Carefully read and follow the instruction in this booklet

Contents

Installation	5
--------------	---

Piping & Venting	14
------------------	----

Start-up	20
----------	----

Operation	22
-----------	----

Maintenance	27
-------------	----

Troubleshooting Guide	33
-----------------------	----

Appendix	34
----------	----

Introduction

Thank you for purchasing a Highland Tank Oil/Water Separator. Highland Tank's patented design combines state-of-the-art technology with time-tested materials, making the Highland Tank Oil/Water Separator the strongest and most reliable high-performance separator in the industry.

The purpose of this manual is to provide detailed information on the installation, venting, startup, operation, maintenance and trouble-shooting of Highland Tank's Oil/Water Separator (OWS). These instructions should be used in conjunction with those provided by the STI Steel Tank Institute (Underground Steel Storage Tanks with ACT-100-U® R971-00 or STI-P3® Corrosion Control System R821-00) and the Petroleum Equipment Institute's PEI/RP 100-97.

Things to think about before you begin:

Carefully read and follow instructions in this booklet. Local codes may apply. Check with local authorities prior to installation of OWS.

- Adequate site space - almost all products are delivered on a 60' trailer. Allow space for positioning and unloading
- Crane with adequate lifting capacity and clearance - have operator check site for clearances - overhead, turning, etc. Spreader bars are required for 10' dia. and larger. Tanks 10' dia. and larger are shipped rotated to minimize over-the-road height. These tanks must be lifted from the hauling trailer by the supplied lifting lugs on the heads of the tank. These tanks must be rotated before final lifting into the excavation. Spreader bars and adequate lifting straps should be available to maintain recommended safe lifting capacity. Please check approval drawing for overall length of the tank and location of the head lifting lugs. Highland Tank does not permit rotating the tanks while they are still on the trailer.
- Special permits may be required for weight, size, etc. by local code.
- Inlet/outlet piping elevations - coordinate with site plan - check/recheck when tank arrives with approval drawing.
- Make sure tank hold-down method/system is predetermined and components are at site for OWS installation.
- The amount of debris such as sand, gravel, dirt, leaves, wood, rags, etc., permitted to enter the OWS must be minimized for maximum effectiveness. Installation of an appropriately sized Series G OWS with integral sand interceptor or an appropriately sized Highland Tank Sand/Oil Interceptor upstream of the OWS, is recommended.
- Detergents and solvents must not enter the separator system. The separator will not remove chemical emulsions or dissolved hydrocarbons and their presence retards the recovery of oil that would otherwise be separated.
- Waste water containing high concentrations of dissolved solids (such as untreated sanitary sewage) must be excluded due to its emulsifying tendency. Waste water which exhibits high BOD (Biological Oxygen Demand), COD (Chemical Oxygen Demand), VOC (Volatile Organic Compound) and TSS (Total Suspended Solids) may require additional treatment after the OWS. Installation of an appropriately sized Highland Tank Advanced Secondary Treatment System is recommended.
- Waste oils (such as automobile and truck crank case oil) should not be intentionally drained into the OWS. Filling the OWS with waste oils adversely affects OWS performance. Waste oil should be dumped into a waste holding tank for proper disposal.
- OWS needs to be maintained to remain as free of accumulated oil and sediment as possible. Suction removal of waste, by what commonly is referred to as a "Vac-All" Truck, is the best method of maintenance.
- The location of your OWS should be in an area with sufficient truck access (top-side clearance) for waste removal.
- An absence of gravity flow to the OWS will necessitate waste-water pumping. Pumping should be restricted to the clean water, effluent end of the separator (Series J OWS literature). If pumping occurs at the influent end, it will tend to mix the oil and water, increasing the emulsified and dissolved oil content, possibly to the point of separation failure. If a pump is installed upstream of the separator, it must be a positive displacement pump (progressive cavity, diaphragm, sliding shoe, etc.), at minimum gpm, and installed as far upstream as possible to minimize oil/water mixing.
- The separator system must be kept from freezing at all times. The separator and piping should be installed below frost line. If necessary, a thermostatically controlled steam or electric heating device may be installed.
- Barricade the OWS installation area until job is complete.
- Complete the OWS Installation Checklist. A copy of the completed installation checklist should be retained by the OWS owner and/or installation contractor.
- Complete the ACT-100-U® or STI-P3® Installer Information Card. This information is required for the Limited Warranty.
- Fill OWS with clean water before introducing any waste water into the OWS.

Underground Installation

OWS Unloading

Each OWS must be mechanically unloaded. Use extreme care when unloading the OWS. Weight distribution may be uneven.

Pre-Installation Inspection

Upon delivery, inspect the OWS for exterior damage that may have occurred during shipping or job site handling.

Carefully remove manway covers so as not to damage the gasket. Inspect the interior of the OWS tank to ensure that all baffles, coalescer plates, coalescer cartridges, and internal piping are secure and have not been damaged during transport.

Excavation and Bedding

The excavation must be free from any hard or sharp material that could cause damage to OWS coating. Be certain that foreign matter is not introduced into the excavation or backfill.

Bedding and backfill must be homogenous material consisting of compacted clean sand, pea gravel, No. 8 crushed stone (ASTM-448), or equivalent.

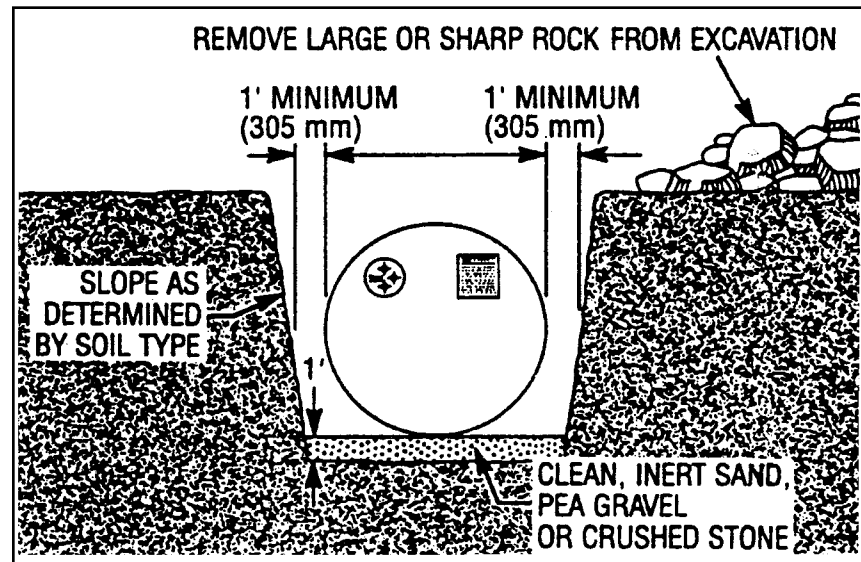

The bottom of the excavation must be covered with bedding material to a depth of one foot, suitably graded and leveled, and extend at least 1 foot around the perimeter of the OWS and anodes (STI-P3® only) for backfill operations.

Excavation and Bedding
(cont'd.)

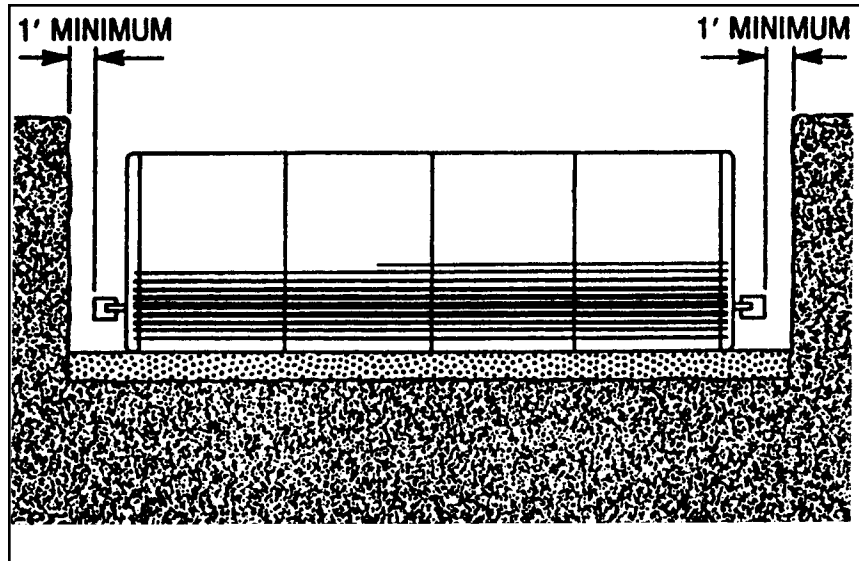

Where anchoring by means of a concrete pad is required, the OWS must not be placed directly on the pad. A layer of bedding material at least 6 inches deep must be spread evenly over the dimensions of the pad to separate the OWS from the pad. The OWS must not be placed on any other hard or sharp material which might cause deformation of the OWS or damage to the coating.

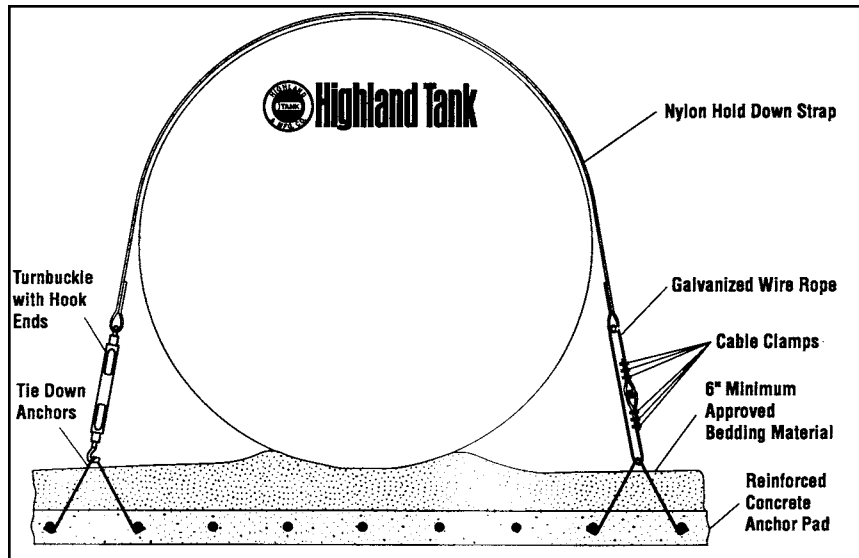

In tidal areas, backfill or bedding materials composed of small particles, such as sand, can migrate into native soils where larger aggregate, such as pea gravel or crushed stone, exists. Resultant voids can create an uneven support for the OWS. The use of filter fabric should be considered.

Above Ground Air Test

Take necessary safety precautions during air tests. Do not leave OWS unattended.

Remove factory-installed temporary plugs and thread protectors. Do not remove the dielectric bushings from the unused openings. Apply compatible, non-hardening pipe sealant to internal bushing threads. Permanent metal plugs must be installed at all unused openings. Do not over-tighten permanent plugs. Do not cross-thread or damage non-metallic bushings when replacing plugs or installing required OWS piping.

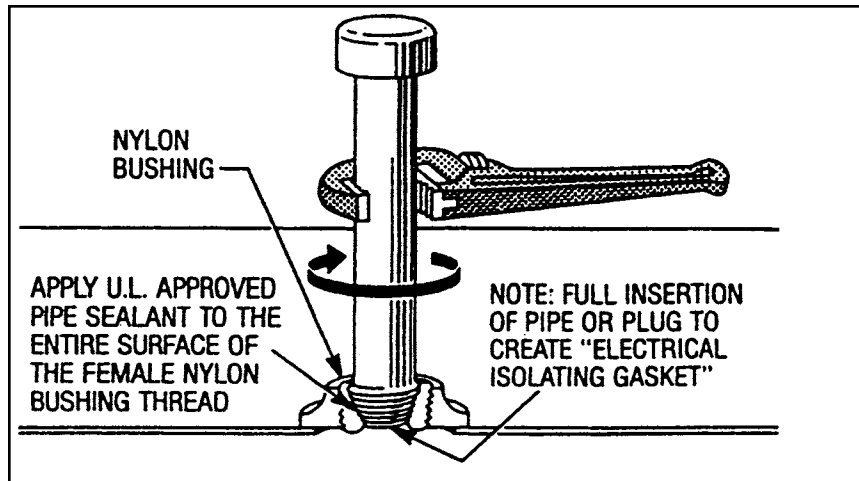

An air test of the single-wall OWS above ground is required. Pressure should not exceed 5

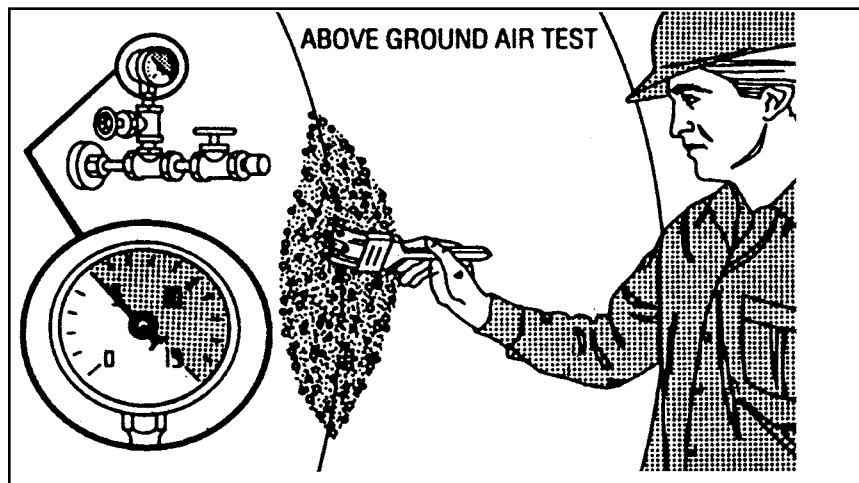

- Double-wall OWS require different air pressure testing procedures. Do not connect a high pressure air line directly to the interstitial monitoring port!

Above Ground Air Test (cont'd.)

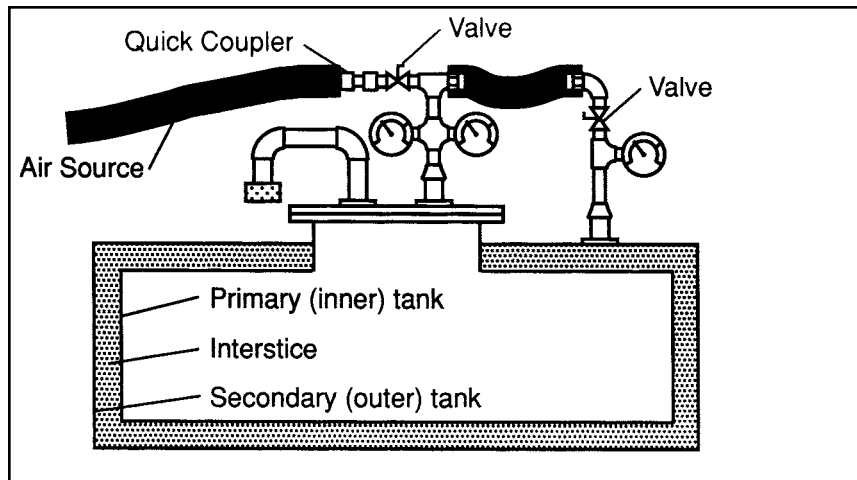

- Pressurize the OWS inner tank to a maximum of 5 PSIG. Seal the inner tank and disconnect the external air supply.
- Monitor the pressure for a period of one hour. While air tests are generally inconclusive without soaping and the careful inspection for bubbles, this step is recommended to detect a very large leak in the inner tank and to prepare for the next step.
- Pressurize the interstice with air from the inner tank. Use a second gauge for measuring pressure in the interstice.
- Soap the exterior of the OWS and inspect for bubbles while continuing to monitor the gauges to detect any pressure drop.
- Release the pressure from the interstice, then release the inner tank test pressure and vent both spaces.
- Vacuum testing of the interstitial space of double-wall OWS can be used in lieu of or in addition to the air test procedure. Do not apply a vacuum to the primary OWS or a single-wall OWS. PEI/RP 100-97 and labels on the tank also provide testing guidelines.

On-Site Standing Hydrostatic Test for EZ-Access Equipped Separators

Single-Wall EZ-Access OWS

An on-site standing water hydrostatic test of the single-wall EZ-Access OWS is recommended to insure no damage has occurred during shipping and handling before installation.

After the separator has been leveled, secured to foundation, and the OWS is fully supported with backfill around the bottom quadrant, fill the OWS with clean, fresh water until water is discharge from the outlet. Allow the OWS to stabilize to a no-flow, static condition.

Measure and record the fluid level accurately from the top of the manway to the static fluid level.

After one hour, verify that the fluid level has not dropped indicating that there may be a leak in the primary tank.

Double-Wall EZ-Access OWS

For double-wall EZ-Access OWS, vacuum testing of the interstitial space can be used instead of the hydrostatic test of the primary separator tank.

A double-wall OWS shipped with a vacuum on the interstice need not be retested, provided the OWS arrives at the installation site with the vacuum level within limits designated by Highland Tank. If the vacuum has decayed during shipment, Highland Tank should be consulted.

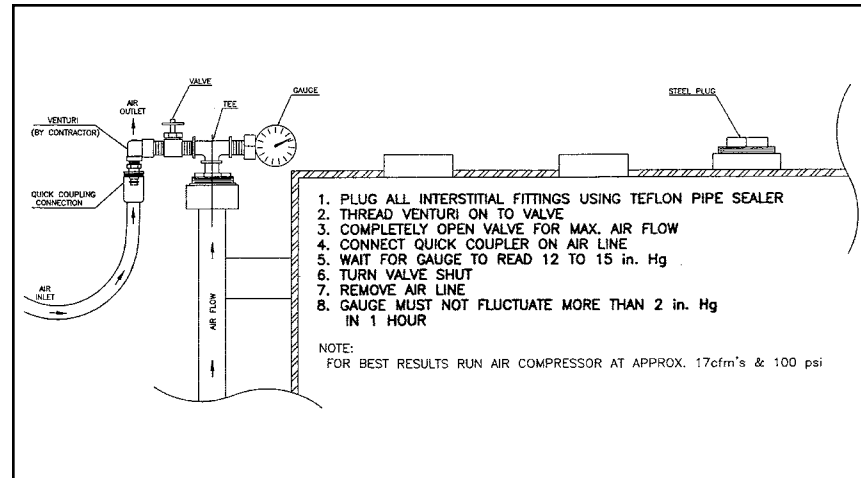

- Do not apply a vacuum to the primary separator tank or a single wall OWS.
- Do not connect the air pressure line from the compressor to the interstitial monitoring port of a double wall OWS.
- After vacuum testing, release vacuum from the separator before dismantling testing equipment.

On-Site Standing Hydrostatic or Vacuum Test for Series G, H, I and J Compartmented Separators

Single-Wall Compartmented OWS

An on-site standing water hydrostatic test of the single-wall Series G, H, I and J compartmented OWS is recommended to insure no damage has occurred during shipping and handling before installation.

After the separator has been leveled, secured to foundation, and the OWS is fully supported with backfill around the bottom quadrant, fill the Oil/Water Separator Chamber ONLY with clean, fresh water until water. Do not overfill chamber to cause flow from transfer pipe(s) into the adjacent chambers. Allow the OWS to stabilize to a no-flow, static condition.

Measure and record the fluid level accurately from the top of the manway to the static fluid level.

Inspect the dry compartments for presence of any water leaking through the bulkheads.

After one hour, verify that the fluid level has not dropped indicating that there may be a leak through the bulkheads.

If no leaks are detected in the adjacent chambers, continue filling OWS until water discharges from the effluent downcomer, or the effluent pumpout chamber is full of water. Check for a static water level drop or leaks around the exterior of the OWS.

For double-wall Series G, H, I, or J OWS, the OWS are shipped with a factory installed vacuum.

Coating Repair

ACT-100-U® OWS's are shipped with a protective isolation board. This board shall be placed on top of the bedding material and the OWS must be placed on the isolation board.

Before placing the OWS in the excavation, all dirt clods and foreign matter must be cleaned from the surface of the OWS. Damage to coating surface must be repaired using the supplied touch-up kit.

Visually inspect the OWS for damage. Pay particular attention to areas where coating has been gouged or abraded. Mark all areas which appear damaged for repair.

Clean damaged OWS coating areas of rust, dirt, contaminants, or disbonded coating prior to application of touch-up coating. Areas of coating damage shall be roughened up with coarse grit sandpaper or grinder (see SSPC SP-2 "Hand Tool Cleaning" or SP-3 "Power Tool Cleaning" for additional guidance) to remove all glossiness from the surface surrounding the repair area approximately 6" around the damaged area. Re-coat the area with touch-up coating provided. Damaged polyurethane coatings must be repaired with the polyurethane repair kit.

Coating Repair (cont'd.)

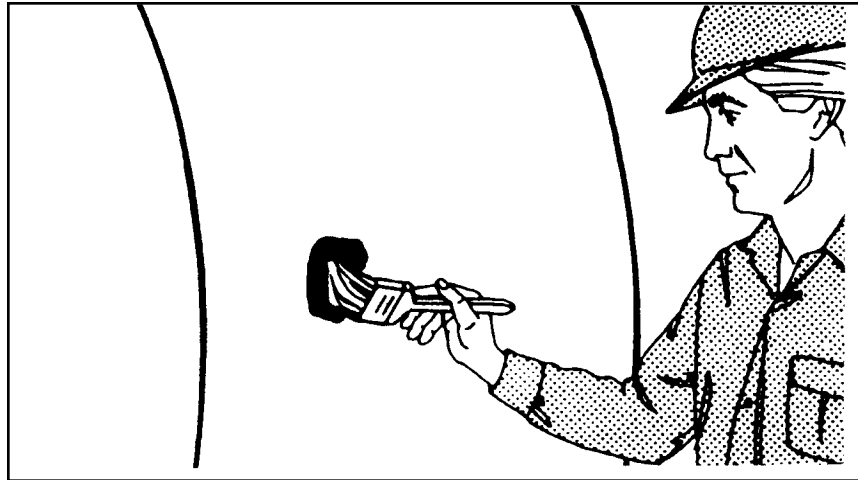

If the OWS is shipped with protective plastic covering over the weld-on anodes, remove this plastic covering. Do not remove cloth bag or cardboard box around anode (STI-P3® only).

OWS Handling

Lifting equipment must be of adequate size to lift and lower the OWS without dragging, dropping or damaging the OWS or its coating.

The OWS must be carefully lifted and lowered with cables or chains of adequate length and attached to the lifting lugs. A spreader bar should be used where necessary. Under no circumstances should chains or slings be used around the OWS shell.

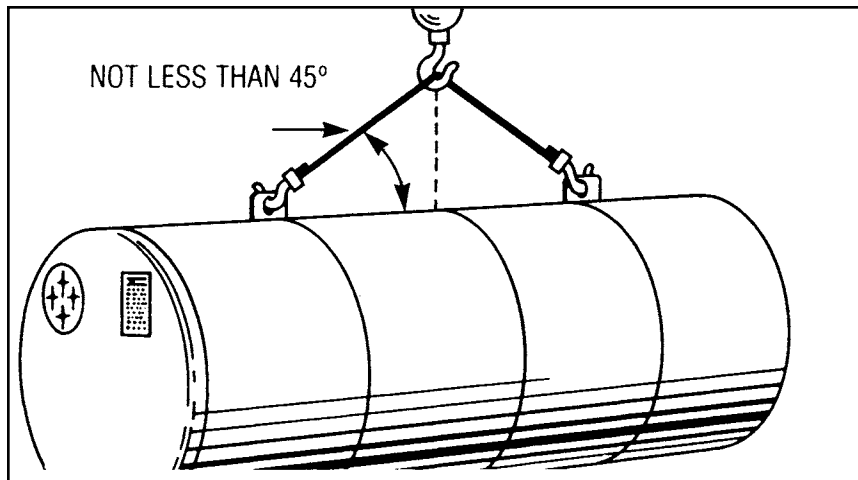

Anode Integrity (STI-P3® only)

STI-P3® OWS's may be equipped with either zinc, magnesium, or combinations of both anodes. Magnesium anodes are designed for installation in soil with a resistivity of 2,000 ohms-cm or greater. Zinc and zinc/magnesium combination anodes are effective in all soil resistivities.

Anode connection (if by a lead wire) must be checked after OWS placement in excavation. If damage to the wire has occurred, the connection must be re-established in strict accordance with STI-P3® specifications.

To ensure immediate operation of cathodic protection system, each anode must be thoroughly saturated with water prior to back filling.

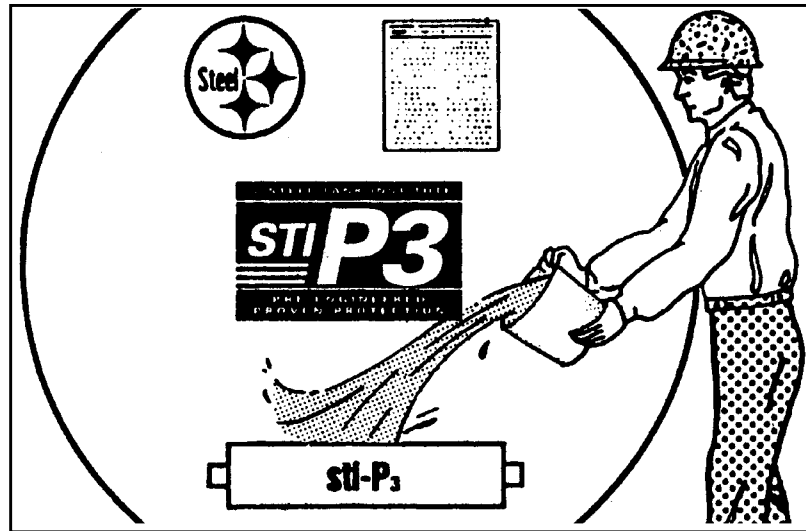

Placement of OWS

The OWS must be installed in a level and plumb position. Check elevations at each end of the OWS with a transit and adjust as necessary to $\frac{1}{2}$ " in 20'-0". Check elevations across the diameter of the OWS and adjust to $\frac{1}{4}$ " in 10'-0".

Anchoring Underground

High water tables or partially flooded excavation sites exert significant buoyant forces on OWS. Buoyant forces are partially resisted by the weight of the OWS, the back fill, and the pavement atop the OWS. Additional buoyant restraint, when required, can be obtained by using properly designed hold down straps in conjunction with concrete hold down pads or dead-man anchors. The use of steel cable and/or round bar as buoyant restraints is prohibited.

Hold down straps must always be kept from contacting the OWS shell by an oversized separating pad made of inert insulating dielectric material.

Anchoring Underground
(cont'd.)

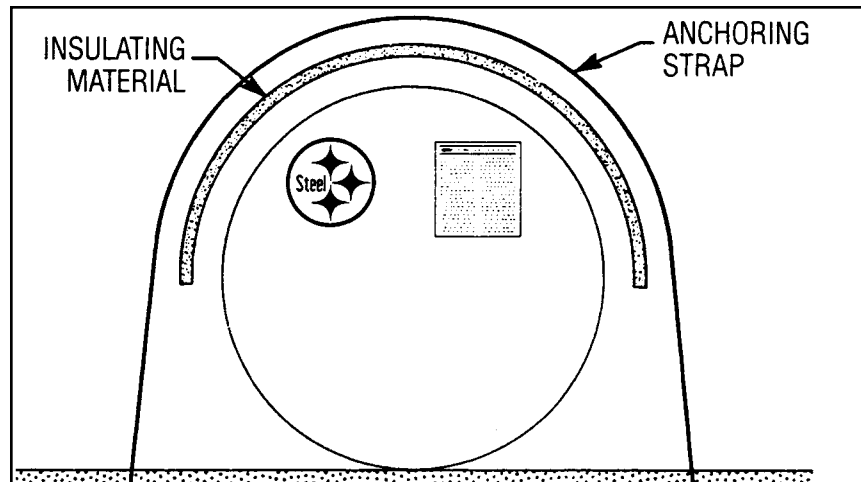

Back-filling Underground

Homogeneous backfill, similar to bedding material, must be placed around the entire OWS to create a uniform homogeneous environment.

Special care must be taken when installing backfill to ensure OWS is fully supported around the bottom quadrant.

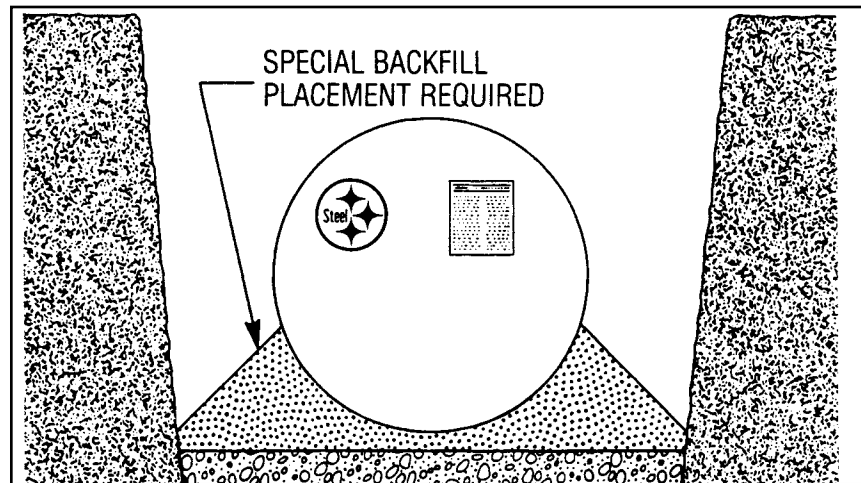

**Back-filling Underground
(cont'd.)**

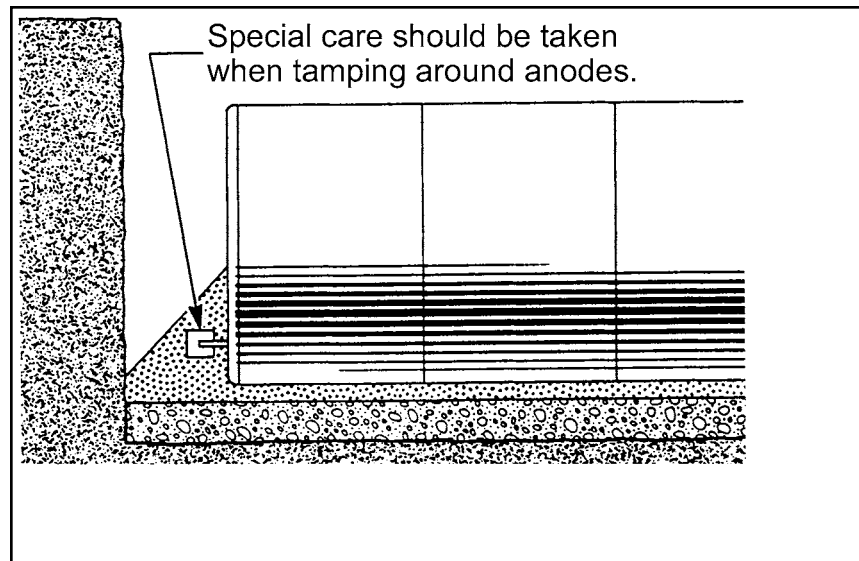

The back-fill should be placed carefully around the OWS just to the top of the OWS.

Fill OWS with clean water ballast. After ballasting is complete, check elevations for proper tolerances.

Piping

- Inlet piping installation should be straight and true with as few turns as possible to limit turbulence.
- The OWS should be fitted with Inlet and Outlet butterfly or gate valves for shutdown during cleaning or in emergency situations.

**Dielectric Isolation for
Piping Underground**

Prior to installation of piping, all openings must be visually inspected to assure that the dielectric nylon bushings remain in place. Where flanged openings have been used (i.e., for the OWS Inlet and Outlet), the dielectric isolation must be confirmed with a continuity tester. Do not allow current to pass across the factory installed dielectric flanges. Dielectric isolation is required to assure the integrity of the corrosion protection system.

**Dielectric Isolation for
Piping Underground
(cont'd.)**

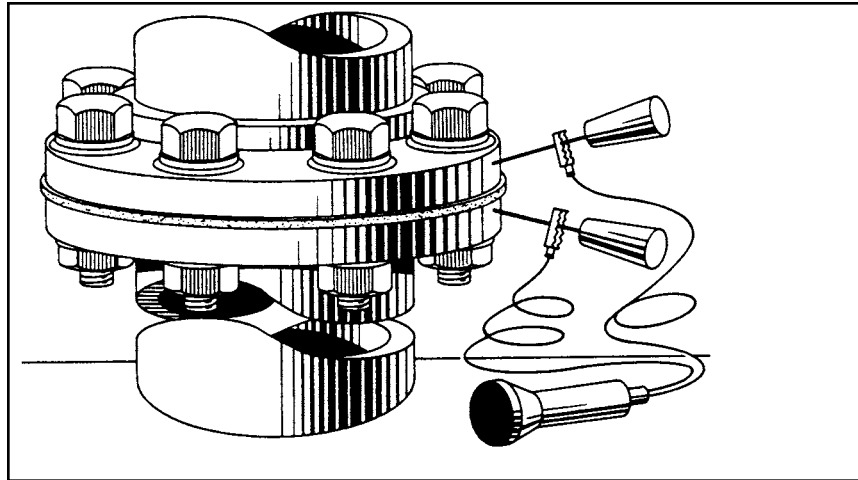

Attach inlet and outlet tees or elbows (contractor supplied) to flanged isolation spools on OWS. Attach inlet and outlet piping to tees or elbows. For OWS with inlet and outlet through OWS heads, attach piping to flanged isolation spools on the inlet and outlet. Inlet and outlet inverts have been established at the factory. Do not modify without first consulting Highland Tank!

The OWS inlet and outlet piping must be sloped at 1/4" per foot to maintain gravity flow. A greater slope, or a free fall of waste water into the OWS, will cause turbulence which adversely affects OWS performance.

OWS inlet piping must be less than or equal to the OWS inlet diameter. OWS outlet piping must be greater than or equal to the OWS outlet diameter.

Attach manway extensions, taking care not to damage manway gasket between manway necks

OWS Venting Guidelines

Separator is designed for operation at atmospheric pressure ONLY. Separator tank inlet, outlet and manways MUST be vented to atmosphere to assure proper operation.

As shown below, the two manway vents can be manifolded together to one common vent line. The inlet and outlet vents must each have their own separate, dedicated vent line.

The reasons for venting the inlet, manways, and outlet are;

- 1 - Tank inlet is vented to prevent hazardous gases from building up in inlet pipe draining the catch basin or trench drain (which may be in a building).
- 2 - Tank outlet is vented to prevent siphoning during full flow into a flooded storm sewer or flooded pit.
- 3 - Tank manways are vented to prevent hazardous gases from building up in manway risers.

The reason for venting the inlet, manways, and outlet independently from one another is to prevent raw oil or oily wastewater from bypassing and exiting the oil water separator tank, through the vent line, to the outlet pipe, in the event of a surge.

**OWS Venting Guidelines
(cont'd.)**

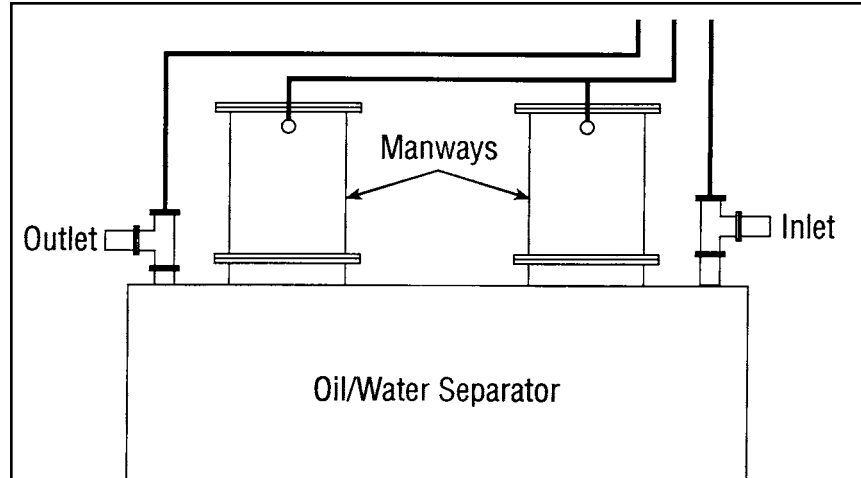

Owners must provide flame arrestors where required by governing codes for safety.

**OWS with Gravity
Oil Skimmers and/or
Monitoring Equipment**

Install oil skimmers and piping. Piping between the OWS and the waste oil tank must be sloped 1/8" per foot to maintain gravity flow.

For OWS's with oil level sensors, pump-out pipes, and leak detection sensors, install riser pipes using compatible non-hardening sealant, taking care not to cross thread or damage the nonmetallic bushings. Torque of 400 to 1,000 ft-lbs. may be required to fully insert pipe. Refer to enclosed manufacturer's sensor and control panel wiring diagrams and installation instructions for electrical details!

Remove thread protectors from unused openings. Do not remove dielectric bushings from unused openings! Permanent metal plugs treated with pipe compound must be installed at all unused openings.

Final Air Test

Air pressure for air or hydrostatic testing after installation must not exceed 5 pounds per square inch (PSIG) and must be measured at the top of the OWS.

**OWS Cathodic Protection
Monitoring System
Installation (STI-P3® only)**

Each STI-P3® Protected OWS must have a cathodic protection monitoring station (PP2® or other) installed so that OWS structure lead is easily accessible and identifiable at the finish grade. This provides for easy attachment of a reference electrode monitoring device.

**Protection Prover 2® (PP2®)
(STI-P3® only)**

If your OWS is equipped with a Protection Prover 2® (PP2®) prior to completion of the back-fill, position the monitoring terminal, located near the top of the OWS, as follows:

Select a terminal location on the 4" diameter Oil Pump Out Pipe that will be accessible through a grade manhole.

Loosen the black nylon pipe lashing by releasing the locking tab. Uncoil enough lead wire from the OWS mounting lug to reach the terminal location with an additional 4 feet of slack.

Secure the PP2® terminal to the pipe by tightening the black nylon pipe lashing. The lead wire terminations must remain sealed.

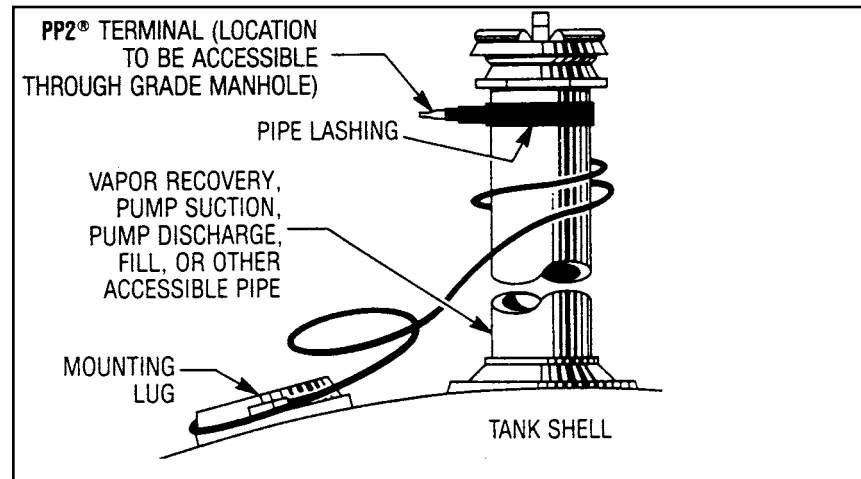

Route wire to avoid strain or breakage during back fill. Do not cover PP2® terminal with back fill material.

**Sealing Lifting Lugs and
Pipe Connections Underground**

Per STI specifications, polyurethane coating has been applied over all steel surfaces. During the installation process, steel can become exposed at the lifting lug due to the handling of the OWS or at the interface between the steel OWS and the electrical isolation fitting. These areas, along with all other exposed steel surfaces, must be covered using the coating kit supplied by the manufacturer. Also, any other exposed steel surfaces must be repaired with this kit. Apply supplied coating touch-up to ACT-100-U® coated OWS; likewise apply supplied polyurethane touch-up coating to STI-P3® coated OWS. After application, the installer must verify that all of the repair work has cured (adequate material hardness and solidification) prior to backfill. Cure time will vary depending on temperature.

After an air test has established tightness, OWS fittings shall receive an application of coating prior to backfill. Coating shall include the entire plug on unused fittings.

**Final System Check
(STI-P3® only) (cont'd.)**

Monitoring is required to confirm proper installation and cathodic protection of the OWS. Check tank-to-soil potential reading before pouring concrete or asphalt pad atop OWS with a high impedance voltmeter and copper/copper sulfate reference electrode. Place reference electrode in moist soil directly above the OWS. A minimum reading more negative than -850 millivolts indicates the anodes are activated. Record reading on Warranty Validation Card, Installer Information Card and other permanent files. Return Installer Information Card to Steel Tank Institute.

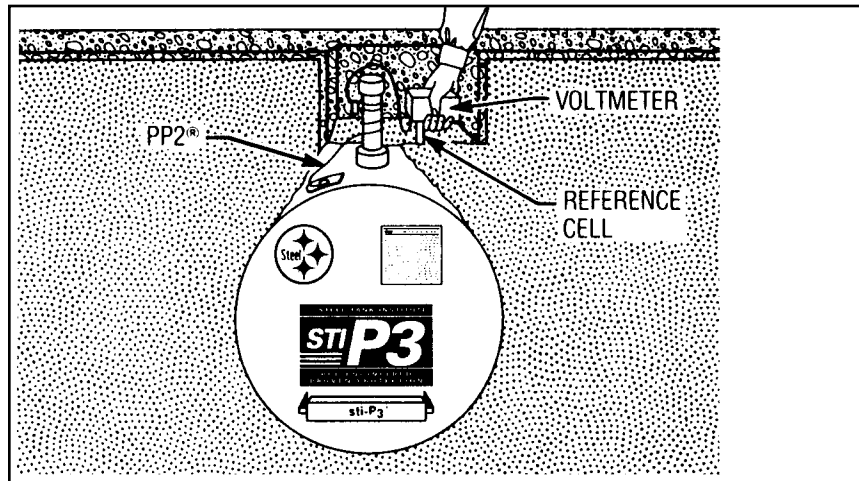

Due to their classification as waste water treatment tanks, OWS's are deferred from Federal UST Regulations and are not required to be monitored at 3-year intervals. The OWS however, should be monitored at installation and whenever maintenance or new constructions occur near site. Follow applicable local, state, and federal regulations for additional requirements. Reference NACE RP-02-85 for more specifics on cathodic protection criteria.

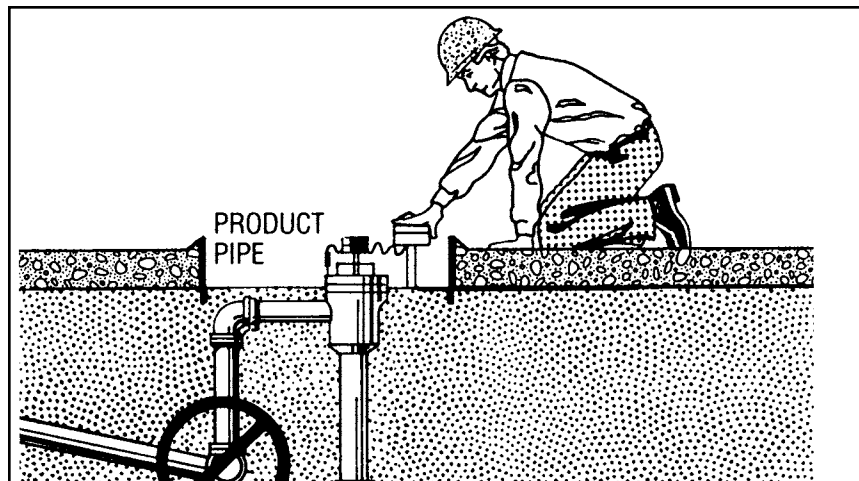

Note: Cathodic protection effectiveness of STI-P3® tanks will be impacted by contact with other metal structures including piping.

Start-Up

Warnings

CAUTION: Separated liquid oil and vapors are flammable and/or combustible.

This system must be properly vented by installer in accordance with applicable plumbing and safety codes for venting of combustible gases.

Purchaser must be sure that the final state of all wiring complies with all applicable electrical and fire code standards.

Service personnel must comply with all established OSHA codes for facility and service. These include, but are not limited to, the use of approved breathing equipment, protective clothing, safety equipment, etc.

All electrical equipment, connections and wiring must be protected from submergence and infiltration of water.

Intrinsically safe sensor wiring must be kept in a separate conduit from non-intrinsically safe power wiring. Run non-intrinsically safe power wiring in steel conduit grounded at the panel end only.

Filling the Tank

Open the OWS inlet and outlet pipe valves.

Fill the OWS with clean, fresh water.

The OWS can be filled through the facility's drain leading to the OWS inlet or through a manway.

If filling by manway, place the hose through the 4" diameter Gauge Port in the Manway Cover or in the 24" diameter Manway so that hose outlet rests inside the OWS.

The OWS is full when water drains out of the Outlet. Check the water level using a gauge stick. The OWS is full when the level on the gauge stick equals the invert of the Outlet Pipe as measured from the OWS bottom.

To ensure that no blockage exists, allow water to flow through the facility drain which leads to the OWS Inlet. Check the Outlet Pipe to make sure that water is flowing through the OWS. Check the Inlet Pipe and facility's drain for water backup.

Prior to Oil Level Sensor Installation

Oil Level Controls (optional)

Check sensor with an OHM Meter. Both switches are normally closed in a low position (dry condition).

and/or

Connect the sensor to proper panel wiring (refer to specific panel wiring diagram supplied).

Switch on the panel.

Move the bottom float up and down on the probe stem. As the bottom float approaches the lower grip ring, High-High Oil Level Warning Alarm (red light and audible alarm) should activate.

Move the top float up and down on the probe stem. As the top float approaches the lower grip ring, the High Oil Level warning alarm (an amber light) should activate.

Note: If one or both alarms do not activate properly, check the panel and sensor wiring for proper connections and continuity.

**After Oil Level
Sensor Installation**

As installed OWS fills with water, both floats will be in low position (dry condition) and both alarms will be activated.

Note: If alarms are not activated, check the wiring connections.

While the OWS is filling with water, the High-High Oil Level Warning Alarm should deactivate, and soon thereafter the High Oil Level Warning Alarm should deactivate.

Note: If the alarms do not deactivate upon filling, remove the sensor and check for float binding or poor electrical connections.

Operation

Standard OWS Description

The Highland Tank OWS is designed specifically for the removal of free floating oil, raw petroleum hydrocarbons, grease, and settleable oily coated solids from petroleum and industrial waste water. The OWS intercepts and collects these pollutants directly from the facility's waste water drainage system and prevents their discharge into the environment.

The Highland Tank OWS will not remove oils with a specific gravity greater than .95, chemical or physical emulsions, dissolved hydrocarbons, solvents, or volatile organic compounds (VOC). (Refer to Highland Tank's Advanced Secondary Treatment System [Brochure HT-2035] for treatment of waste water contaminated with these pollutants.)

Important: For proper operation, the OWS must be filled with water at all times.

CAUTION: Separated liquid oil and vapors are flammable and/or combustible.

Any and all oil recovered and removed from the OWS should be recycled or disposed of in accordance with federal, state and local regulations.

The OWS is a stationary, wastewater treatment tank, filled with water. Internal baffles and coalescers accelerate the oil/water separation process. Waste accumulates within the separator while effluent is discharged by gravity.

During operation, the wastewater enters the top of the OWS through the Inlet Nozzle and is directed over the Velocity Head Diffusion Baffle, a heavy metal plate, inclined at a 45° angle. The Velocity Head Diffusion Baffle serves four basic functions:

- Dissipates the velocity of the incoming water, thereby improving the overall hydraulic characteristics of the separator.
- Directs the flow downward and outward maximizing the use of the separator volume.
- Reduces flow turbulence and distributes the flow evenly over the separator's cross-sectional area.
- Isolates the inlet turbulence from the rest of the separator.

In the Sediment Chamber, heavy solids settle out and are collected behind the Sludge Baffle. Concentrated oil slugs rise immediately to the surface.

As the oily water passes through the Parallel Corrugated Plate Coalescer (an inclined arrangement of parallel corrugated plates), the oil rises and coalesces into sheets on the underside of each plate. The oil then creeps up the plate surface and breaks loose at the top in the form of large globules. These globules then rise rapidly to the surface of the Separation Chamber, where the separated oil accumulates.

The efficiency of oil/water separation is remarkably improved by increasing the effective separation surface area through the use of multiple, stacked parallel corrugated plates.

The maximum distance that an oil particle has to rise for effective removal is the distance between the corrugated plates.

The corrugated plates are inclined at an upward angle and spaced $\frac{3}{4}$ " to 3" apart (depending on the application) to prevent fouling by debris and gummy solids.

Effluent flows downward to the Outlet Downcomer, where it is discharged by gravity displacement.

Free-floating oils and greasy solids accumulate until they are pumped out of the OWS.

**PETRO-SCREEN™ Coalescer
(for Model HTC only)**

For enhanced oil removal efficiency, a PETRO-SCREEN™ Coalescer is used to intercept droplets of oil too minute to be removed by the Parallel Corrugated Plate Coalescer.

The PETRO-SCREEN™ is a bundle of oleophilic (oil attracting) polypropylene fibers, layered from coarse to fine, and encased in a solid frame.

When the waste water enters the PETRO-SCREEN™, residual oil globules in the water, down to 20 microns in size, become attached to the oleophilic fibers. Once attached, the oil globules coalesce, increasing their size and accelerating their rising rate. When sufficiently large, the globules break free and rise rapidly to the surface of the Separation Chamber, where the separated oil accumulates.

Oil Level Controls (Optional)

Refer to Control Panel information in Appendix.

For easy, efficient operation and maintenance, the OWS is equipped with an Oil/Water Interface and Level Sensor to activate warning alarms at high oil levels in the OWS.

Oil accumulates in the OWS until a predetermined level is reached, at which time the oil level sensor activates an alarm signaling that the OWS is full of oil. The level sensor is a magnetic float switch type for oil/water interface detection.

- One (1) Channel Alarm/Control Panel. Refer to Control System HT-1AS.

This alarm/control panel is used in conjunction with a single oil/water interface float switch. The panel will have the nametage "Alarm" over the visual indicating light.

When the oil/water interface reaches a point reflecting 20% OWS volume, one inch below the Oil Pump-Out Pipe, the single oil/water interface float switch is activated and the indication light and audible alarm signals that the OWS Tank is full of oil.

Important: This alarm warns that the OWS is full of oil and the oil will need to be pumped out soon.

- Two (2) Channel Alarm/Control Panel. Refer to Control System HTAP2.

The panel will have the nametages "Alarm No. 1" and "Alarm No. 2" over the visual indicating lights.

This alarm/control panel is used in conjunction with:

- a Dual High Oil/High-High Oil oil/water interface float switch

There are two alarm sensors on one stem:

- High Oil Level Warning Alarm

When the oil/water interface reaches a point reflecting 20% OWS Tank volume, one inch below the Oil Pump-Out Pipe, the upper oil/water interface sensor is activated and an Alarm No. 1 visual indication light signals that the OWS is full of oil.

Important: This alarm warns that the OWS is full of oil and the oil will need to be pumped out soon.

- High-High Oil Level Warning Alarm

In the event that the OWS Tank is not maintained or in the event of an oil spill condition, the oil/water interface will continue to drop. Once the oil/water interface reaches a point reflecting 43% OWS volume, the lower oil/water interface sensor is activated and the Alarm No. 2 visual indication light and audible horn signals that the OWS is dangerously full of oil.

Important: This alarm alerts the operator that the oil must be removed immediately.

Oil Level Controls
(Optional) (cont'd.)

- A High Oil oil/water interface float switch and a Liquid Only Leak Detection Sensor

When the oil/water interface reaches a point reflecting 20% OWS volume, one inch below the Oil Pump-Out Pipe, the single oil/water interface float switch is activated and the indication light and audible alarm signals that the OWS is full of oil.

Important: This alarm warns that the OWS is full of oil and the oil will need to be pumped out soon.

For easy and efficient monitoring of the annular space, the OWS is equipped with a Liquid Only Leak Detection Sensor to activate warning alarms in the Alarm/Control Panel if the annular space is filled with hydrocarbons or water.

- Two (2) Channel ALarm/Control Panel. Refer to Control System A-HI-LDFW.

This alarm/control panel is used in conjunction with a single oil/water interface float switch and a Fuel/Water Leak Detection Sensor.

The panel will have the nametags "High Oil / Leak" over the visual indicating lights. This control panel will have fuel/water test pushbuttons.

When the oil/water interface reaches a point reflecting 20% OWS volume, one inch below the Oil Pump-Out Pipe, the single oil/water interface float switch is activated and the indication light and audible alarm signals that the OWS is full of oil.

Important: This alarm warns that the OWS is full of oil and the oil will need to be pumped out soon.

For easy and efficient monitoring of the annular space, the OWS is equipped with a Fuel/Water Leak Detection Sensor to activate warning alarms in the Alarm/Control Panel if the annular space is filled with hydrocarbons or water.

During operation, if the audible alarm is energized, it can be silenced by momentarily depressing the Silence push-button. However, to determine if this is a Fuel or a Water leak, continue with the following instructions:

Fuel Push-Button: (when audible alarm is already silenced)

Momentarily depress the Fuel Push-Button. If after release of the button, the audible alarm energizes, this indicates a fuel leak. The audible alarm can be silenced by again depressing the Silence push-button.

Water Push-Button: (When audible alarm is already silenced)

Momentarily depress the Water Push-Button. If after release of the button, the audible alarm energizes, this indicates a water leak. The audible alarm can be silenced by again depressing the Silence push-button.

If fuel or water is present in the annular space, pump out liquid and consult Highland Tank.

Oil Level Controls
(Optional) (cont'd.)

- Three (3) Channel Alarm/Control Panel. Refer to Control System A-LDFW.

This alarm/control panel is used in conjunction with a dual oil/water interface float switch and a Fuel/Water Leak Detection Sensor.

The panel will have the nametags "High Oil/High-High Oil/Leak" over the visual indicating lights. This control panel will have fuel/water test pushbuttons.

This alarm/control panel is used in conjunction with:

- A dual Oil/High-High Oil oil/water interface float switch.

There are two alarm sensors on one stem:

- High Oil Level Warning Alarm

When the oil/water interface reaches a point reflecting 20% OWS volume, one inch below the Oil Pump-Out Pipe, the upper oil/water interface sensor is activated and an Alarm No. 1 visual indication light signals that the OWS is full of oil.

Important: This alarm warns that the OWS is full of oil and the oil will need to be pumped out soon.

- High-High Oil Level Warning Alarm

In the event that the OWS is not maintained or in the event of an oil spill condition, the oil/water interface will continue to drop. Once the oil/water interface reaches a point reflecting 43% OWS volume, the lower oil/water interface sensor is activated and the Alarm No. 2 visual indication light and audible horn signals that the OWS is dangerously full of oil.

Important: This alarm warns that the OWS is full of oil and the oil must be removed immediately.

For easy and efficient monitoring of the annular space, the OWS is equipped with a Fuel/Water Leak Detection Sensor to activate warning alarms in the Alarm/Control Panel if the annular space is filled with hydrocarbons or water.

During operation, if the audible alarm is energized, it can be silenced by momentarily depressing the Silence push-button. However, to determine if this is a Fuel or a Water leak, continue with the following instructions:

Fuel Push-Button: (when audible alarm is already silenced)

Momentarily depress the Fuel Push-Button. If after release of the button, the audible alarm energizes, this indicates a fuel leak. The audible alarm can be silenced by again depressing the Silence push-button.

Water Push-Button: (When audible alarm is already silenced)

Momentarily depress the Water Push-Button. If after release of the button, the audible alarm energizes, this indicates a water leak. The audible alarm can be silenced by again depressing the Silence push-button.

If fuel or water is present in the annular space, pump out liquid and consult Highland Tank.

At the end of all Oil Recovery Operations, the operator must refill the OWS with water. The multi-station liquid level control is then automatically reset.

Leak Detection System
(Optional)

Refer to Control Panel information in Appendix.

For easy and efficient monitoring of the annular space, the OWS is equipped with a Liquid Leak Detection Sensor to activate warning alarms if the annular space becomes filled with hydrocarbons or water during operation.

If the audible alarm is activated during operation, it can be silenced by momentarily depressing the SILENCE push-button.

If fuel or water is present in the annular space, pump out liquid and consult Highland Tank for further information.

Maintenance

CAUTION: Separated liquid oil and vapors are flammable and/or combustible.

WARNING: Never enter an OWS or enclosed space, under any condition, without proper training and OSHA approved equipment. (Consult OSHA guidelines 29 CFR, Part 1910 "Permit Required Confined Spaces.")

All enclosed spaces must be properly vented prior to entry to avoid ignition of flammable materials or vapors.

Atmosphere must be properly tested for combustible vapors and oxygen prior to entry.

Entering the OWS without using a self-contained breathing apparatus may result in inhalation of hazardous fumes, causing headache, dizziness, nausea, loss of consciousness, and death.

Required entry equipment includes, but is not limited to:

- Lifelines
- Safety harnesses (safety belts are unacceptable)
- Self-contained breathing apparatus
- Respirators (canister type)
- Rescue harness and ropes
- Horns, whistles, radios, etc. (for communication purposes)
- Explosion-proof lighting

Important: Be sure to inspect and replace manway gaskets as necessary when the OWS is shut-down for maintenance.

The coalescer plates and packs can be removed for cleaning or can be cleaned from above using a hot-water pressure wash with extension wand.

Mechanical lifting is required to remove the coalescer packs in large diameter OWS.

Inlet and effluent pipe valves should be closed prior to OWS entry.

All liquid must be removed from the OWS prior to entry.

Any and all oil recovered and removed from the OWS should be recycled or disposed of in accordance with federal, state, and local codes and regulations.

CAUTION: Interior surfaces of the OWS will be slippery.

OWS are designed for long-term, trouble-free operation. The following maintenance should be performed as needed or in accordance with a facility maintenance schedule.

Periodic inspection of:

- Upstream trench drains, sand interceptors, and traps
- Inside of the OWS for sand, trash, sludge and oil build-up
- Effluent for oils and other contaminants in accordance with local codes and permits
- Oil level in accordance with local codes and permits

OWS's with oil level sensors require oil removal when the alarm is activated. Simply remove the oil, then refill OWS with clean water (see Start-Up Instructions).

OWS's without oil level sensors require level checking by use of a gauge stick with oil/water sensing paste. If oil/water interface level is below that shown on the Oil Level Chart, oil needs to be removed and the OWS refilled with clean water.

WARNING: If the oil is not pumped out, the oil concentration in effluent may exceed the desired levels. Oil should only be removed during non-flow conditions to ensure pure oil draw-off.

Maintenance (cont'd.)

If contaminants are found, close the valve on the inlet line, determine what the requirements are for restoring working order and take appropriate action.

For optimum performance, maintenance is required as needed or at least:

Once per year or when:

Bottom sludge in tank is 12" deep;

The effluent exhibits an oil sheen or contains high contaminant levels.

Inspect OWS after a heavy rainfall to check for signs of malfunction due to an excessive flow rate.

If the OWS has been cleaned within the year and only bottom sludge has built up while the effluent water is contaminant free, it may be sufficient to vacuum the sludge from the sediment chamber and refill OWS with clean water. (See Start-Up Instructions.)

Oil Removal Procedures

Important: Oil should only be removed during non-flow conditions to ensure pure oil draw-off.

Oil Removal Procedures (with optional oil level controls)

Be sure the High Oil Level Warning Alarm is activated because of an actual high oil level, otherwise a mixture of oil and water will be removed.

To minimize water contamination of the oil, connect the oil suction hose to the 4" diameter Oil Pump-out Pipe fitting/coupling.

Suction out the oil.

Refill OWS with clean water to deactivate the High Oil Level Warning Alarm. (See Start-Up Instructions.)

Oil Removal Procedures (without optional oil level controls)

Determine where the oil/water interface by using a gauge stick and oil/water sensing paste.

If the oil/water interface is less than the level found on the Oil Level Chart for your model, suction out the surface oil from the 4" diameter Gauge Port or the manway, otherwise a mixture of oil and water will be removed.

If the oil/water interface is equal to or greater than the level found on the Oil Level Chart, connect the oil suction hose to the 4" diameter Oil Pump-out Pipe fitting/coupling and suction out the oil.

Mixed Oil and Water
Removal Procedures

Place a 3" or smaller suction hose inside the OWS through either the 4" diameter Gauge Port or through the Sediment Chamber Manway.

The suction hose nozzle should be 12" or higher above the OWS bottom. If nozzle extends closer to the bottom, sludge may be inadvertently removed.

Suction out OWS contents.

Refill with clean water. (See Start-up Instructions.)

Major Oil Spill
Response Procedures

Important: A major oil spill is a spill which exceeds the normal oil storage capacity of the OWS. In the event of a major spill, notify proper authorities as required by federal, state, and local laws.

After a major oil spill, the OWS should always be emptied, cleaned, and refilled with clean water.

Oil Spill Removal Procedures (with or without optional oil level controls)

If OWS has optional oil level controls, be sure the High and High-High Oil Level Warning Alarms are activated because of an actual High-High oil condition.

Determine exactly where the oil/water interface is located using a gauge stick and oil/water sensing paste.

Open the 4" diameter Gauge Port or Sediment Chamber Manway.

Apply oil/water sensing paste to a gauge stick.

Place gauge stick into the OWS through the 4" diameter Gauge Port or Manway to determine the oil/water interface location.

Place a 3" diameter or smaller suction hose inside the OWS through either the 4" diameter Gauge Port or through the Manway.

Lower hose to exact oil/water interface location. If the suction hose nozzle extends lower than the oil/water interface, water may be inadvertently removed with the oil.

Suction out the oil.

Refill with clean water. (See Start-Up instructions.)

If oil is still visible on the surface of the OWS or the alarms remain on, suction out the oil and refill with clean water.

Continue this sequence until only a sheen of oil is visible on the surface of the OWS or the alarms deactivate.

Sludge Removal Procedures

Determine exactly where the sludge/water interface is located using a wooden gauge stick.

Open the 4" diameter Gauge Port or Sediment Chamber Manway.

Place gauge stick into the OWS through the 4" diameter Gauge Port or Manway.

Slowly lower the gauge stick until it comes into contact with the sludge blanket. Mark the stick.

Push the stick downward until it comes into contact with the Striker Plate on the OWS bottom. Mark the stick.

The sludge depth is the difference between the two measurements.

Sludge Removal Procedures (for full OWS)

Place a 3" diameter or smaller suction hose inside the OWS through either the 4" diameter Gauge Port or through the Manway.

Lower hose to exact sludge/water interface location.

Suction out the sludge while slowly lowering the suction hose nozzle until it comes into contact with the Striker Plate on the OWS bottom.

Refill with clean water. (See Start-Up Instructions.)

Sludge Removal Procedures
(cont'd.)

Sludge Removal Procedures (for completely empty OWS)

Warning: Never enter an OWS or enclosed space, under any condition without proper training and OSHA approved equipment (Consult OSHA guidelines 29 CFR, Part 1910 "Permit Required Confined Spaces").

Suction out sludge and debris. Use caution to avoid internal coating damage.

Using a standard garden hose at normal pressure (40-70 PSIG), with or without a spray nozzle, loosen any caked oily solids. Use of hot water can be helpful.

Direct the water stream to the OWS wall side and bottom.

Suction out the resultant slurry.

General OWS Cleaning
Procedures

If not properly maintained, the OWS may malfunction.

NOTE: Over a period of time sediment, oil, and grease will build up on the walls and floors of the OWS. Dirt and heavy oil may also build up on the Parallel Corrugated Plate Coalescer reducing the unit's efficiency. Also, the PETRO-SCREEN™ removes some suspended solids along with the small oil droplets in the wastewater. Periodic cleaning of the PETRO-SCREEN™ is also required.

Important: It is recommended that the OWS be cleaned as needed or at least once a year. Keep inspection and maintenance logs and have them available for ready reference.

Sediment Chamber

Remove manway cover to expose the Sediment Chamber being careful not to damage the gasket.

Pump-out contents of OWS (see Mixed Oil and Water Removal Procedures).

Gauge the level of sand, dirt, or debris with wooden gauge stick.

Important: The level of sand, dirt, or debris should not be allowed to accumulate higher than 12" from the bottom of the OWS.

Remove the accumulated waste with a suction hose (See Sludge Removal procedures).

Direct a high pressure hose downward to loosen any caked oily solids on OWS sides and bottom.

NOTE: Use of high-temperature, high-pressure washing equipment along with Highland Cleaner can be helpful in OWS cleaning. Highland Cleaner is very effective and is 100% Biodegradable, non-emulsifying, and contains no Linear Activated Solvents (LAS), Phosphates, Ammonia, or Acids.

Attach spray nozzle wand extension to the high pressure hose.

Direct spray downward and toward the velocity head diffusion baffle to loosen up any caked oily solids that may have accumulated on inlet head.

Direct the spray to the OWS wall sides, top and bottom.

Remove the slurry with the suction hose.

Oil Water Separator Chamber

Disconnect all non-voltage carrying sensor lines to the Oil Level Sensor.

Carefully remove the Oil Level Sensor.

Carefully check the Oil Level Sensor floats. If the floats do not slide easily on the stem or have sludge on them, clean the Oil Level Sensor. Use a parts washer and mineral spirits to remove accumulated oil, grease, or sludge.

Check the Oil Level Sensor with an OHM meter to assure proper operation.

Place the Oil Level Sensor in a safe area to prevent damage.

Remove manway cover over the 24" diameter manway to expose the Oil Water Separation Chamber.

Be careful not to damage the gasket.

Gauge the level of sand, dirt, or debris with wooden gauge stick.

Remove the accumulated waste with a suction hose (see Sludge Removal Procedures).

Direct a high pressure hose downward and around to loosen caked oily solids on OWS sides, top and bottom.

Attach spray nozzle wand extension to the high pressure hose.

Direct spray downward and toward the Parallel Corrugated Plate Coalescer to loosen up caked oily solids that may have accumulated on top of plates.

Flush the Parallel Corrugated Plate Coalescer from the outlet side to direct debris to Sediment Chamber.

NOTE: The coalescer packs must be cleaned of all sludge to operate properly.

Direct the spray to the OWS wall sides, top and bottom. Rotate the nozzle sufficiently and often so that all areas are reached with the spray.

PETRO-SCREEN™ Coalescer

Important: Coalescer packs CAN BE cleaned in place or removed for cleaning. Mechanical lifting equipment is required to remove the coalescer packs in larger units.

Hook the Lifting Rod to the Lifting Lug on the coalescer pack and remove the coalescer pack directly below the manway.

Using the Lifting Rod, slide the next coalescer pack over and remove.

Continue until all coalescer packs have been removed and are above grade.

Place coalescer packs on oil absorbent blanket or sheet plastic.

NOTE: The coalescer packs should be moved to a convenient location upstream of the separator and washed to remove any gummy deposits.

Using a standard garden hose at normal pressure (40–70 PSIG) — with or without a spray nozzle — loosen any caked solids.

Flush the coalescer packs from both sides.

Let coalescer packs stand and dry.

PETRO-SCREEN™ Coalescer
(cont'd.)

Visually inspect the OWS interior and components for any damage.

NOTE: If any visual damage exists, contact Highland Tank for further instructions.

Reinstall the coalescer packs.

The coalescer packs must be installed sitting on top of the bottom steel channel supports.

NOTE: Improper installation will result in separator malfunction.

Reattach the manway cover. Ensure the gasket is damage free.

Install the Oil Level Sensor in the 2" diameter Interface and Level Sensor Pipe.

Reconnect all non-voltage carrying sensor lines to the Oil Level Sensor.

Refer to OWS Start-Up Instructions for proper refilling and restarting procedures.

Troubleshooting Guide

Problems which occur during OWS operation can be the result of many factors. The following list identifies the most common problems, their possible causes and suggested remedies.

PROBLEM	POSSIBLE CAUSE	REMEDY
Excessive oil concentrated in OWS effluent water.	Storm water pumped into the OWS (causing emulsification of oil droplets in the clean water).	Change to gravity flow.
	Flow rates exceeding rated capacity (causing emulsification of oil droplets in the clean water).	Decrease flow.
	Presence of detergents or surfactants (causing with Highland Cleaner.	Detect and remove source of harmful chemical emulsification). Replace detergents.
	Oil levels higher than rated storage capacity, causing separated oil to carry-over.	Remove oil.
	Excessive flow turbulence into OWS (causing more mechanical emulsions).	Check for debris in inlet piping. Decrease flow.
	Presence of dissolved hydrocarbons	Remove source of hydrocarbon.
	Presence of excessive dissolved or suspended solids leading to OWS, inside OWS, or in effluent. (Solid or clay may be coated with oil).	Install Highland Interceptor Tank in front of OWS and clean OWS.
	Oil is of a higher specific gravity than was specified for OWS.	Remove source of high specific gravity oil, or decrease flow rate and install heater in OWS.
	Wastewater pH is high (causing chemical	High pH is usually caused by high alkaline
Storm water back-up in drainage area.	Excessive sludge or debris build-up.	Clean out OWS.
	Closed inlet or effluent piping valves.	Open piping valves completely.
	Inlet piping vapor lock. properly.	Check to ensure inlet tee vent is operating properly.
	Debris. Interceptor.	Clean catch basin, trench drains, and/or
High suspended solids content in clean water effluent.	Excessive sludge or debris build-up.	Clean out OWS.
	Excessive solids in storm water drainage area.	Install Highland Interceptor Tank in front of OWS and clean OWS.

If you have any questions regarding OWS problems, and for information on control panels, please contact Highland Tank.

OWS Reference Drawing

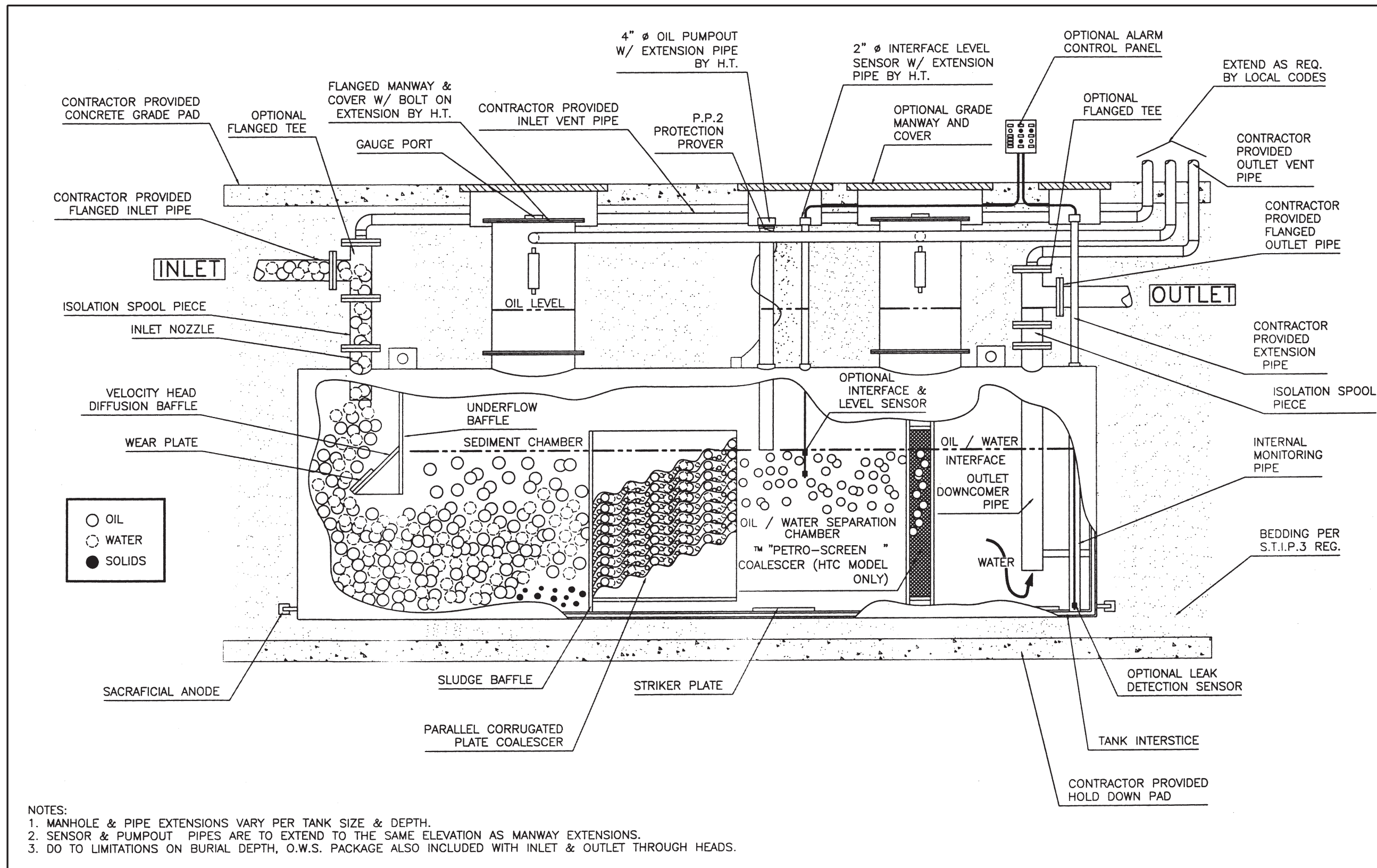



Highland Tank

Highland Manufacturing Locations

One Highland Road
Stoystown, PA 15563-0338
(814) 893-5701
FAX 893-6126

2225 Chestnut Street
Lebanon, PA 17042
(717) 664-0602
FAX 664-0631

99 West Elizabethtown Road
Manheim, PA 17545-9410
(717) 664-0600
FAX 664-0617

2700 Petterson Street
Greensboro, NC 27407
(336) 218-0801
FAX 218-1292

958 19th Street
Watervliet, NY 12189
(518) 273-0801
FAX 273-1365

1510 Stoystown Road
Friedens, PA 15541
(814) 443-6800
FAX 444-8662

Please visit us at www.highlandtank.com