

GENERAL SPECIFICATIONS

NO. REQ'D: (1)
 CAPACITY: 200 GALLONS
 TYPE: RECTANGULAR, HTC, ABOVEGROUND, SINGLEWALL
 MATERIAL: MILD CARBON STEEL
 FLOW RATE: 10 GPM
 GAUGE:
 SHELL- 7 GA
 HEADS- 7 GA
 SURFACE PREP:
 SSPC NO.10 BLAST ALL INTERIOR SURFACES
 SSPC NO.6 BLAST ALL EXTERIOR SURFACES
 COATING: MATERIAL THICKNESS
 EXTERIOR- FINISH PAINT WHITE
 INTERIOR- POLYURETHANE (3 MILS)
 CONSTRUCTION: (15 MILS)
 BUTT FIT & WELD ALL CORNERS IN & OUT

NOTES

- ALL INTERNAL MATERIAL IS 10 GA
- ALL DRAINS MUST SHIP W/ STEEL PLUGS INSTALLED
- LIFTING LUGS HAVE REINFORCING PLATES

PROVIDED EQUIPMENT

- 3"x3"x1/4" FLAT W/ 9/16"Ø HOLE DRILLED IN CENTER (GROUNDING LUG)
- SEDIMENT CHAMBER
- OIL WATER SEPARATOR CHAMBER
- FNPT THREADED INLET
- PVC INLET ELBOW PIPING
- VELOCITY HEAD DIFFUSION BAFFLE - 10GA
- WEAR PLATE - 1/4"
- REMOVABLE PARALLEL CORRUGATED PLATE COALESCER (CORELLA PVC PLATES) 1" PLATE SPACING
- SLUDGE BAFFLE - 10GA
- PVC OUTLET DOWNCOMER PIPE
- FNPT THREADED OUTLET
- (4) PIECE COVER - 10 GA
- NUTS & BOLTS W/ LARGE WING NUTS-TYP. (CORROSION RESISTANT)
- GASKET MATERIAL (FOR EACH REMOVABLE COVER)
- 3"Ø FNPT (CLEAN-OUT)
- 2"Ø FNPT (VENT)
- 2"Ø FNPT HALF COUPLING (DRAIN) W/ STEEL PLUG
- 3"Ø FNPT FULL COUPLING W/ 3"Ø INTERNAL PVC PIPE (OIL PUMPOUT)
- 2"Ø FNPT HALF COUPLING (INTERFACE LEVEL SENSOR)
- 2"Ø 90° ELBOW W/ 2" HALF COUPLING ON TOP WITH PVC RISER PIPE
- 7 GA BRACING ACROSS TOP OF TANK W/ SENSOR & PUMP-OUT FITTINGS
- LIFTING LUGS
- 2"Ø FERNCO COUPLING
- 6" THICK PETROSCREEN COALESCER MATERIAL
- HANDLES PER H.T. STANDARD
- 1" Ø FNPT COUPLING W/ PLUG

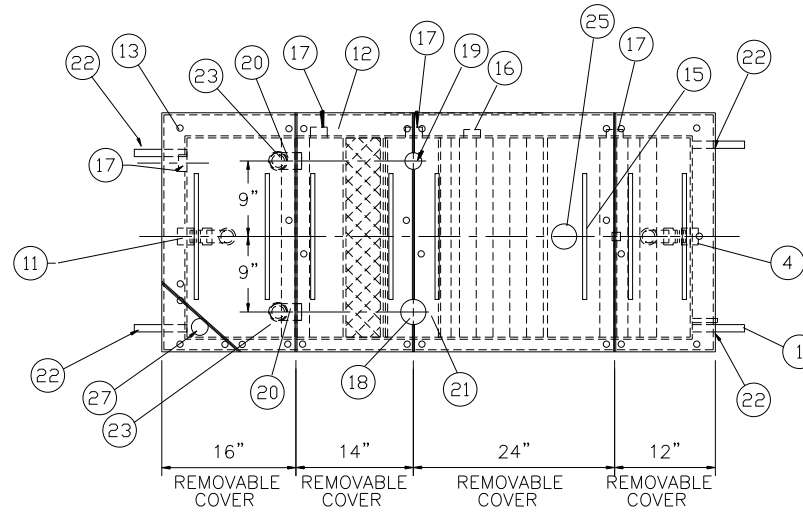

PLAN

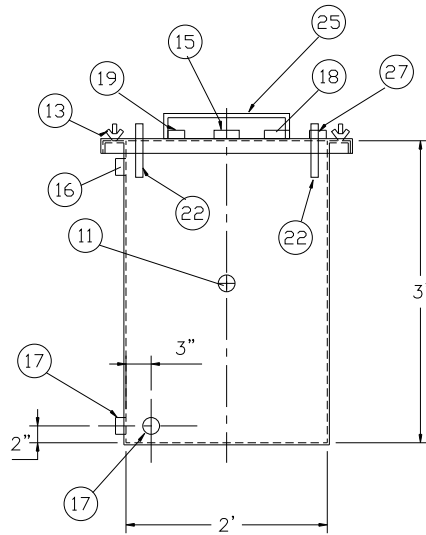

END VIEW

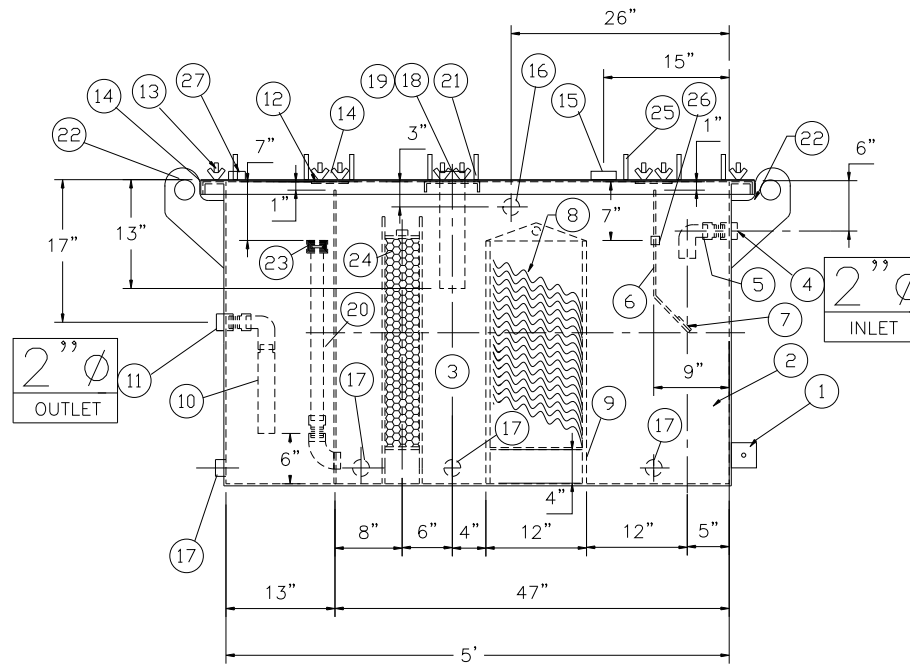

ELEVATION

NOTE:
 ALL RIGHTS RESERVED. THIS DRAWING OR ANY PART THEREOF MUST NOT BE REPRODUCED IN ANY FORM WITHOUT THE WRITTEN PERMISSION OF HIGHLAND TANK.
 HIGHLAND TANK SHALL BE RESPONSIBLE ONLY FOR ITEMS INDICATED ON THIS FABRICATION DRAWING UNLESS OTHERWISE NOTED. CUSTOMER IS RESPONSIBLE FOR VERIFYING CORRECTNESS OF SIZE / LOCATION OF FITTINGS, ACCESSORIES & COATINGS SHOWN ON THIS DRAWING

REVISIONS



Highland Tank

U.S. Patent #4,722,800 Canadian Patent # 1,296,263
 #6,606,224 # 2,389,065

200 GALLON OIL WATER SEPARATOR
 RECTANGULAR, HTC, SINGLE WALL

CUSTOMER:

PROJECT:

QUOTE NO:

CHK'D BY:

UNLESS OTHERWISE SPECIFIED DIMENSIONS ARE IN INCHES
 TOLERANCES ARE + OR - 1"

SCALE: 3/4"=1'-0" DATE: 5-20-05

DWG. BY:

DWG. NO.: 00200RECSWHTC