

GENERAL SPECIFICATIONS

NO. REQ'D: (1)
 CAPACITY: 7000 GALLON
 TYPE: HT, HIGHGUARD, SINGLE WALL
 MATERIAL: MILD CARBON STEEL
 FLOW RATE: 700 GPM

GAUGE:
 SHELL- 1/4"
 HEADS- 1/4"

SURFACE PREP:
 SSPC NO.6 BLAST ALL EXTERIOR SURFACES

COATING: MATERIAL THICKNESS
 EXTERIOR- POLYURETHANE (75 MILS)
 INTERIOR- NONE

CONSTRUCTION : LAP FIT & WELD ALL EXTERIOR SEAMS
 OPERATING PRESSURE : ATMOSPHERIC

NOTES:

- POLYURETHANE HIGHGUARD TANK IS NOT APPROVED FOR THE STORAGE OF HEATED PRODUCTS
- ALL VENT PIPING BY INSTALLER
- 15000 VOLT SPARK TEST PROVIDED AT FACTORY

PROVIDED EQUIPMENT

- 150# R.F.S.O. FLANGE
- 2"Ø FTG. FOR VENT TYP. BOTH MANWAYS.
- VELOCITY HEAD DIFFUSION BAFFLE
- WEAR PLATE
- SEDIMENT CHAMBER
- UNDERFLOW BAFFLE
- SLUDGE BAFFLE
- STRIKER PLATES
- PARALLEL CORRUGATED PLATE COALESCER. CORELLA PVC PLATES
- OIL/WATER SEPARATOR CHAMBER
- 4"Ø FTG. FOR GAUGE WITH PLUG TYP. BOTH MANWAYS.
- OUTLET DOWNCOMER
- 24"Ø MANWAY WITH BOLT-ON EXTENSION SHIPPED LOOSE
- 4"Ø FTG. FOR OIL PUMPOUT W/INTERNAL PIPE INSTALLED & RISER PIPE SHIPPED LOOSE
- 2"Ø FTG. FOR LEVEL SENSOR W/ RISER PIPE SHIPPED LOOSE.
- LIFTING LUG

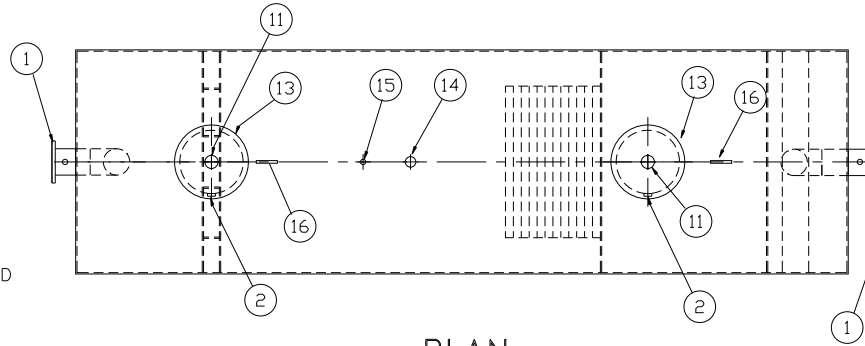

PLAN

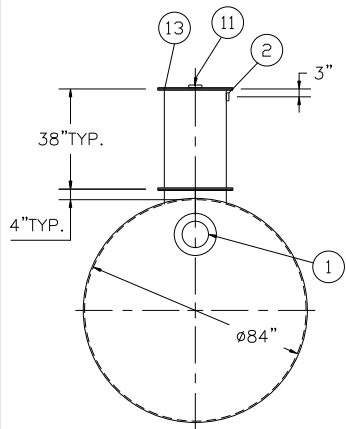

END VIEW

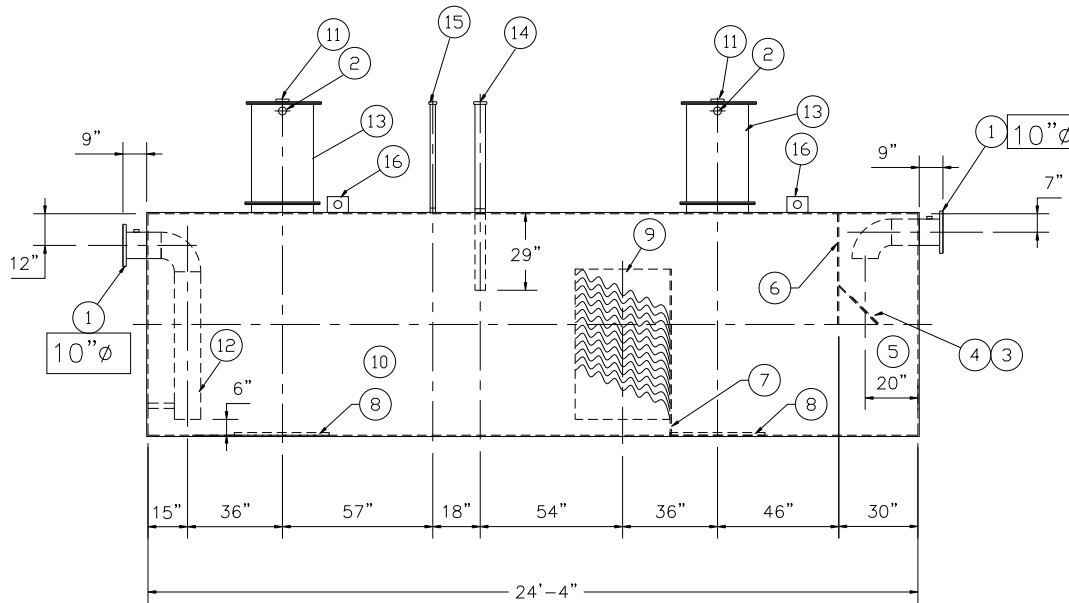

ELEVATION

NOTE :
 ALL RIGHTS RESERVED. THIS DRAWING OR ANY PART THEREOF MUST NOT BE REPRODUCED IN ANY FORM WITHOUT THE WRITTEN PERMISSION OF HIGHLAND TANK.
 HIGHLAND TANK SHALL BE RESPONSIBLE ONLY FOR ITEMS INDICATED ON THIS FABRICATION DRAWING UNLESS OTHERWISE NOTED. CUSTOMER IS RESPONSIBLE FOR VERIFYING CORRECTNESS OF SIZE / LOCATION OF FITTINGS , ACCESSORIES & COATINGS SHOWN ON THIS DRAWING

REVISIONS	
 Highland Tank U.S. Patent #4,722,800 Canadian Patent # 1,296,263 #6,606,224 # 2,389,065	
7000 GALLON OIL WATER SEPARATOR HT, HIGHGUARD, SINGLE WALL	
CUSTOMER:	
PROJECT:	
QUOTE NO:	CHK'D BY:
SCALE: 1/4"=1'-0"	DATE: 8-1-07
DWG. BY:	DWG. NO.: 07000HGSWHTHDS