

NOTE: ALL RIGHTS RESERVED. THIS DRAWING MUST NOT BE REPRODUCED IN ANY FORM WITHOUT THE WRITTEN PERMISSION OF HIGHLAND TANK®. HIGHLAND TANK® SHALL BE RESPONSIBLE ONLY FOR ITEMS INDICATED ON THIS FABRICATION DRAWING UNLESS OTHERWISE NOTED. CUSTOMER IS RESPONSIBLE FOR VERIFYING CORRECTNESS OF SIZE AND LOCATION OF FITTINGS, ACCESSORIES, AND COATINGS SHOWN ON THIS DRAWING.

TOUCH UP OF FINISHED PAINT IS REQUIRED BY INSTALLATION CONTRACTOR. TOUCH UP PAINT SHIPPED WITH TANK.

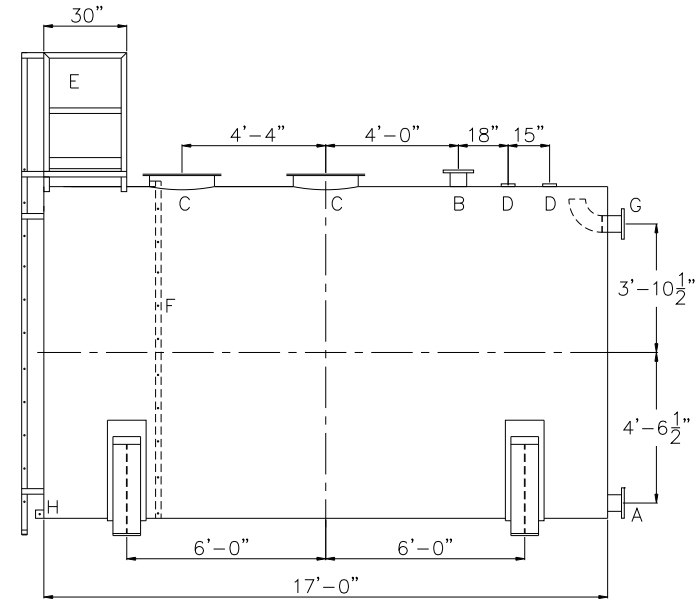
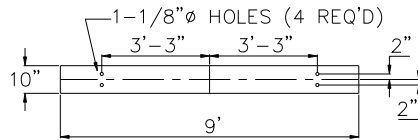
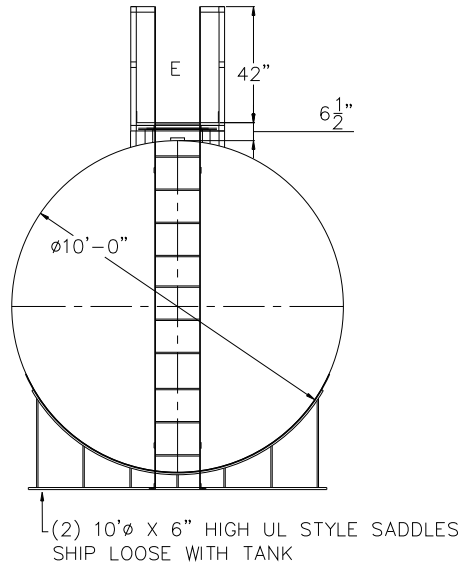

DESIGN DATA

CAPACITY - 10,000 GALLONS
TYPE - POTABLE WATER TANK (PWT)
NO. REQ. -
OPERATING PRESSURE - ATMOSPHERIC
TANK MATERIAL - MILD CARBON STEEL
THICKNESS: HEADS - 5/16"
THICKNESS: SHELL - 1/4"
CONSTRUCTION - LAP WELD INSIDE & OUTSIDE
TANK TEST - 5 PSIG
INT. FINISH - SP10 BLAST HighDRO®-LINER PLUS FOR NSF 61 APPLICATIONS
EXT. FINISH - SSPC SP6 BLAST, WHITE URETHANE PAINT
LABEL - NONE

LEGEND

A	FLANGE - SUPPLY
B	FLANGE - VENT
C	24" X 1/4" PLATE TIGHT BOLT MANWAY WITH 1/8" THICK NEO-CORK GASKET
D	4" FNPT CONNECTION
E	STD HTM EXTERNAL LADDER & PLATFORM ASSEMBLY - PAINTED SAFETY YELLOW AND SHIPPED LOOSE FOR INSTALLATION ON SITE BY OTHERS
F	HTM STD INTERNAL LADDER
G	FLANGE WITH INTERNAL 90° ELBOW SHOWN - OVERFLOW
H	FB-3" x 1/4" x 3" WITH 5/8"Ø HOLE ON CL (GROUNDING LUG)

 Highland Tank®	
HighDRO® WATER STORAGE TANK 10,000 GAL 120"Ø AH POTABLE WATER TANK	
CUSTOMER:	
PROJECT:	
QUOTE NO:	CHK'D BY:
SCALE: 1/4" = 1'-0"	DATE: XX/XX/XX
DWG. BY: XXX	DWG. NO: 10000AHSWHPWT120