



storage tanks

bulk storage drums

HT-1094

PRODUCT DETAILS

Bulk Storage Drums are designed to be practical and economical. They conveniently store more product in less space than 55-gallon drums and allow for bulk purchasing at lower prices. BDH tanks are helpful when limited height is desired.

Bulk Storage Drums are also available as a vertical tank and include a forklift entry feature for safe, easy handling. Both are built to UL-142 standards and are available in single-wall and double-wall designs.

Standard Features

- » Superior steel welded design
- » Welded fittings with plugs for shipping
- » Primer paint
- » UL-142 Listed
- » 100% Product compatibility

Typical Uses

- » Emergency gas storage
- » Diesel generator storage
- » Motor fuels
- » Lubricants
- » Waste oils

Options

- » Saddle, skid or stabilizer supports
- » Secondary containment dikes
- » Pump platforms
- » Pumps and dispensers

Stabilizers

Stabilizers are used to maintain the tank's position and are the simplest support system available from Highland. Stabilizers do not provide any clearance for visual inspection of the tank underside.

Skids

Skids provide portability for empty horizontal tanks, stabilize the tank and maintain a fixed elevation if being moved. Skids also provide clearance for visual inspection of the tank underside. Highland manufactures two styles of skids; Skids on tanks up to 1,500 gallons are fabricated from steel angle, and large tank skids are fabricated from steel pipe.

Saddles

Saddles are used to support the tank, maintain its position and elevation to provide clearance for visual inspection of the underside. Highland manufactures to the UL-142 two-saddle design standard that facilitates quicker, more trouble-free installations. Concrete pier construction information is available upon request. Standard saddles provide 6" of clearance and are available up to 12" high.

practical & economical

Horizontal - BDH

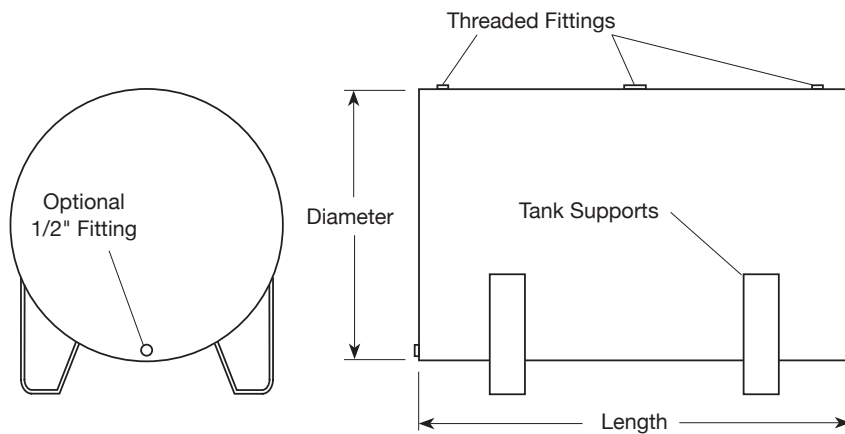

Vertical - BDV

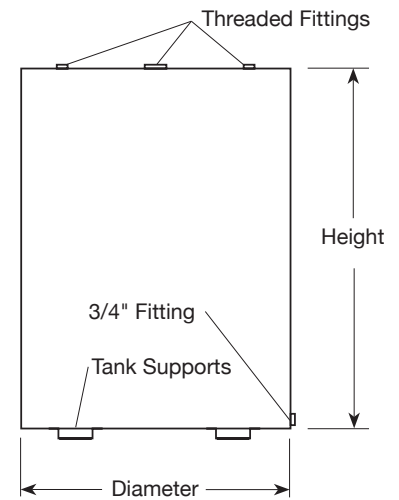

BDH Tanks

Model	Volume Gallons	Inside Tank Dimensions*		Thickness Gauge
		Diameter	Length	
BDH - 240	240	3'-2"	4'-0"	12 ga
BDH - 300	300	3'-2"	5'-0"	12 ga
BDH - 500	500	4'-0"	5'-5"	12 ga
BDH - 1000	1,000	4'-0"	10'-9"	10 ga
BDH - 1500	1,500	5'-4"	9'-0"	7 ga
BDH - 2000	2,000	5'-4"	12'-0"	7 ga



BDV Tanks

Model	Volume Gallons	Inside Tank Dimensions*		Thickness Gauge
		Diameter	Height	
BDV - 240	240	3'-2"	4'-0"	12 ga
BDV - 300	300	3'-2"	5'-4"	12 ga
BDV - 500	500	4'-0"	5'-9"	7 ga



Available in single-wall or double-wall design. Finish paint optional.

Consult factory for double-wall capacities, dimensions and weights.



Stoystown, PA
One Highland Road
Stoystown, PA 15563-0338
814.893.5701

Manheim, PA
4535 Elizabethtown Road
Manheim, PA 17545-9410
717.664.0600

Watervliet, NY
958 19th Street
Watervliet, NY 12189-1752
518.273.0801

Greensboro, NC
2700 Patterson Street
Greensboro, NC 27407-2317
336.218.0801

Lebanon, PA
2225 Chestnut Street
Lebanon, PA 17042-2504
717.664.0602

Friedens, PA
1510 Stoystown Road
Friedens, PA 15541-7402
814.443.6800

Clarkston, MI
4701 White Lake Road
Clarkston, MI 48346-2554
248.625.8700

Mancelona, MI
9517 Lake Street
Mancelona, MI 49659-7968
231.587.8412



PROUDLY MADE IN AMERICA