



storage tanks



chemical storage drums

HT-1002

PRODUCT DETAILS

Bulk Chemical Drums (BCD) are portable, practical and economical. Designed for the handling and storage of very high viscosity fluids, they conveniently store more product in less space than 55-gallon drums.

The BCD bulk size reduces handling and labor time. Strong and durable, they can be reused, eliminating drum disposal and associated costs and environmental impact. BCDs allow for bulk purchasing at lower prices and are also convenient when limited working or storage height is available.

Bulk Chemical Drums are available in vertical or horizontal orientations. Vertical BCDs include a 4-way forklift entry feature for safe, easy handling. Both are built to UL-142 standards and are available in single-wall and double-wall designs.

Horizontal BCD Supports

Stabilizers, the simplest support system, maintain the tank's position and do not provide any clearance for visual inspection of the tank underside.

Skids provide portability for empty horizontal tanks, stabilize the tank and maintain a fixed elevation if being moved. Skids also provide clearance for visual inspection of the tank underside.

Saddles support the tank, maintain it's position and elevation to provide clearance for visual inspection of the underside.

practical & economical

Ideal Uses

- » Grease
- » Paste
- » Mastics
- » Web Inks
- » Body Sealers
- » Caulking

Standard Features

- » Superior steel welded design
- » Welded fittings with plugs for shipping
- » Primer paint
- » UL-142 Listed
- » 100% Product compatibility

Options

- » Exterior Coatings
- » Internal Linings
- » Pump platforms
- » Level Gauges
- » Stainless-steel Construction
- » Stacking Ring

Vertical - BCDV

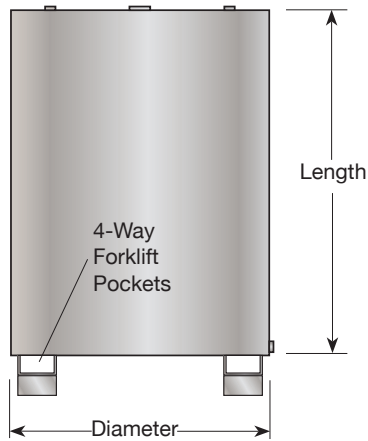

Horizontal - BCDH

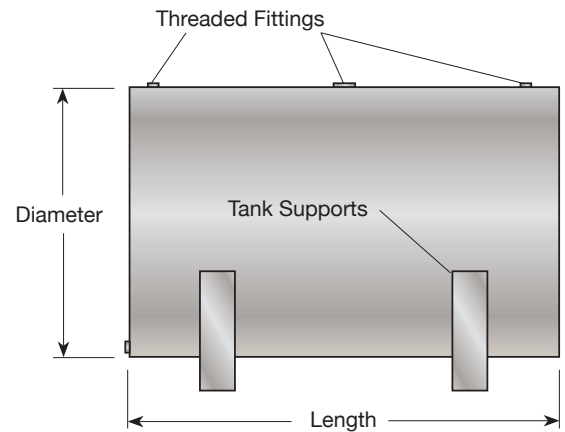
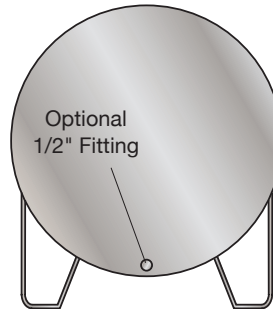

BCDV Tanks

Model	Volume Gallons	Inside Tank Dimensions*		Thickness Gauge
		Diameter	Height	
BCDV - 240	240	3'-2"	4'-0"	12 ga
BCDV - 300	300	3'-2"	5'-4"	12 ga
BCDV - 500	500	4'-0"	5'-9"	7 ga



BCDH Tanks

Model	Volume Gallons	Inside Tank Dimensions*		Thickness Gauge
		Diameter	Length	
BCDH - 240	240	3'-2"	4'-0"	12 ga
BCDH - 300	300	3'-2"	5'-0"	12 ga
BCDH - 500	500	4'-0"	5'-5"	12 ga
BCDH - 1000	1,000	4'-0"	10'-9"	10 ga
BCDH - 1500	1,500	5'-4"	9'-0"	7 ga
BCDH - 2000	2,000	5'-4"	12'-0"	7 ga



Highland Tank®

Manheim, PA
4535 Elizabethtown Road
Manheim, PA 17545-9410
717.664.0600

Watervliet, NY
958 19th Street
Watervliet, NY 12189-1752
518.273.0801

Greensboro, NC
2700 Patterson Street
Greensboro, NC 27407-2317
336.218.0801

Lebanon, PA
2225 Chestnut Street
Lebanon, PA 17042-2504
717.664.0602

Friedens, PA
1510 Stoystown Road
Friedens, PA 15541-7402
814.443.6800

Clarkston, MI
4701 White Lake Road
Clarkston, MI 48346-2554
248.625.8700

Mancelona, MI
9517 Lake Street
Mancelona, MI 49659-7968
231.587.8412



PROUDLY MADE IN AMERICA