



## Chemical Storage Drums

HT-1002

Bulk Chemical Drums (BCD) are portable, practical and economical. Designed for the handling and storage of very high viscosity fluids, they conveniently store more product in less space than 55-gallon drums.

The BCD bulk size reduces handling and labor time. Strong and durable, they can be reused, eliminating drum disposal and associated costs and environmental impact. BCDs allow for bulk purchasing at lower prices and are also convenient when limited working or storage height is available.

Bulk Chemical Drums are available in vertical or horizontal orientations. Vertical BCDs include a 4-way forklift entry feature for safe, easy handling. Both are built to UL-142 standards and are available in single-wall and double-wall designs.

### Horizontal BCD Supports

Stabilizers, the simplest support system, maintain the tank's position and do not provide any clearance for visual inspection of the tank underside.

Skids provide portability for empty horizontal tanks, stabilize the tank and maintain a fixed elevation if being moved. Skids also provide clearance for visual inspection of the tank underside.

Saddles support the tank, maintain it's position and elevation to provide clearance for visual inspection of the underside.

### Standard Features

- Superior steel welded design
- Welded fittings with plugs for shipping
- Primer paint
- UL-142 Listed
- 100% Product compatibility

### Options

- Exterior Coatings
- Internal Linings
- Pump platforms
- Level Gauges
- Stainless-steel Construction
- Stacking Ring

# Drawing & Details

## Vertical - BCDV

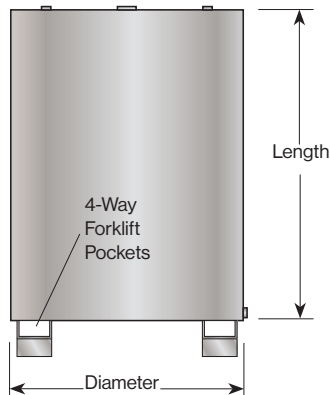

## Horizontal - BCDH

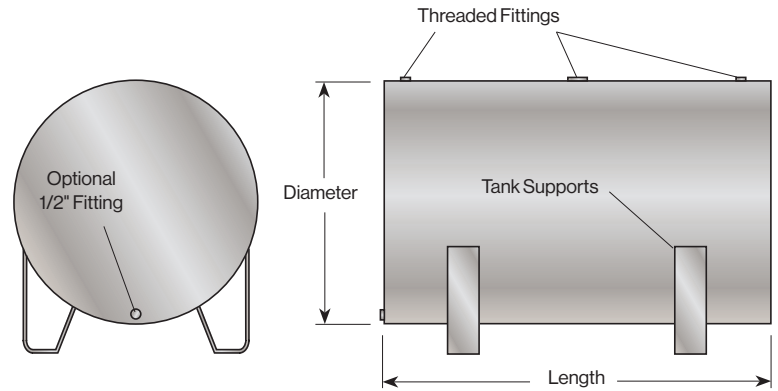

### BCDV Tanks

Volume Model	Gallons	Nominal Inside Dimensions*		Thickness Gauge
		Diameter	Height	
BCDV - 240	240	3'-2"	4'-0"	12 ga
BCDV - 300	300	3'-2"	5'-4"	12 ga
BCDV - 500	500	4'-0"	5'-9"	7 ga

**Ideal Uses:**  
Grease, Paste, Mastics, Web Inks, Body Sealers and Caulking

### BCDH Tanks

Volume Model	Gallons	Nominal Inside Dimensions*		Thickness Gauge
		Diameter	Height	
BCDH - 240	240	3'-2"	4'-0"	12 ga
BCDH - 300	300	3'-2"	5'-0"	12 ga
BCDH - 500	500	4'-0"	5'-5"	12 ga
BCDH - 1000	1000	4'-0"	10'-9"	10 ga
BCDH - 1500	1500	5'-4"	9'-0"	7 ga
BCDH - 2000	2000	5'-4"	12'-0"	7 ga



**Stoystown, PA**  
One Highland Rd.  
Stoystown, PA 15563  
(814) 893-5701

**Manheim, PA**  
4535 Elizabethtown Rd.  
Manheim, PA 17545  
(717) 664-0600

**Watervliet, NY**  
958 19th St.  
Watervliet, NY 12189  
(518) 273-0801

**Greensboro, NC**  
2700 Patterson St.  
Greensboro, NC 27407  
(336) 218-0801

**Friedens, PA**  
1510 Stoystown Rd.  
Friedens, PA 15541  
(814) 443-6800

**Clarkston, MI**  
4701 White Lake Rd.  
Clarkston, MI 48346  
(248) 625-8700

**Mancelona, MI**  
9517 Lake St.  
Mancelona, MI 49659  
(231) 587-8412