



storage tanks

**hopper series aboveground****HT-1032****PRODUCT DETAILS**

Highland Tank Hoppers are compact, low-profile state-of-the-art technology for secondarily contained, aboveground storage. They are suitable for the storage of all types of liquid fuels, new and used oils, waste solvents and antifreeze.

Available in nine convenient capacities, we have a hopper to meet all of your site-specific requirements. All Highland hoppers are designed and built to UL 142 specifications.

Each Hopper consists of an inner tank, placed in the second tub-like steel container, which provides a minimum of 110% secondary containment. The unique, extended top design prevents rain, snow and debris from collecting in the secondary containment.

Elevation supports and a 2" interstitial monitoring pipe and primer paint are included on all models.

Rated for storage of flammable or combustible liquids, the Petro-Hopper is suitable for storing gasoline, kerosene, or diesel fuel. Haz-Hoppers are specifically engineered for the storage of waste oil or waste thinner.

Fuel-Hoppers are designed for storing flammable and combustible liquids such as heating oil or generator fuel.

## Fuel-Hopper

Designed for storage of flammable and combustible liquids such as heating oil.

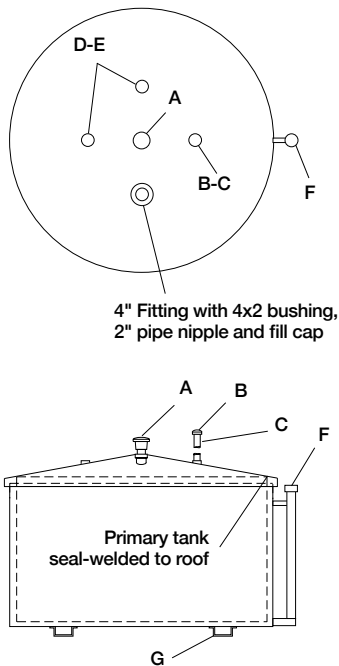

## Haz-Hopper

Designed for storage of waste oil or waste thinner.

Also includes:

- 12" x 16" Access opening with 10" quick-opening fill
- 2" Fitting with 2" dip tube and quick connect

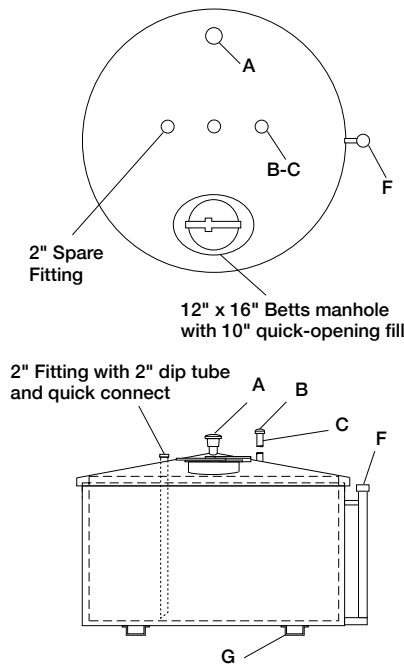

## Petro-Hopper

Designed for storage of flammable or combustible liquids such as kerosene, gasoline and diesel.

Also includes:

- Gauge
- 12" x 18" spill container with aluminum lid

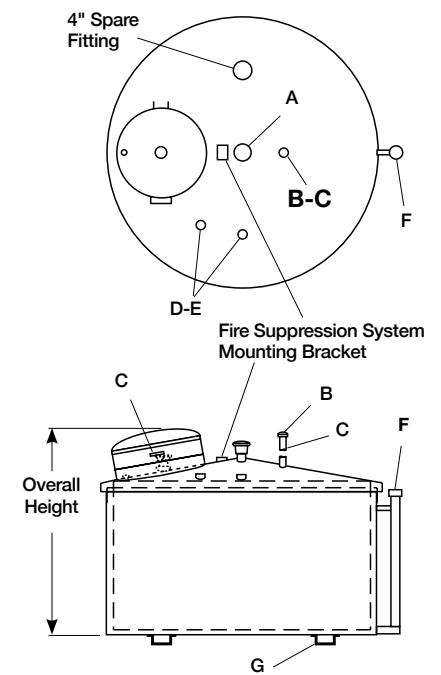

Volume Gallons	Inner Tank Diameter	Height	Outer Tank Diameter	*Overall Height
120	30"	40"	32"	61"
185	38"	40"	40"	60"
285	46"	40"	50"	61"
500	62"	40"	66"	62"
1,000	84"	42"	90"	64"
1,500	96"	48"	102"	71"
2,000	108"	51"	114"	74"
2,500	108"	62"	114"	85"
3,000	108"	73"	114"	96"

\*Approximate overall height for Petro-Hopper. Fuel-Hopper and Haz-Hopper are shorter.

All Highland hopper tanks include:

- (A) - 4" or 6" Emergency vent
- (B) - Mushroom (normal) vent
- (C) - 2" x 8" Vent pipe
- (D) - 2" Suction fitting
- (E) - 2" Gauge fitting
- (F) - 2" Interstitial monitoring pipe
- (G) - Tank supports

Standard accessories vary on Hopper Series Tanks. See below. A limited number of options are available such as pump mounts and red, blue, green, yellow or white finish paint.



**Stoystown, PA**  
One Highland Road  
Stoystown, PA 15563-0338  
**814.893.5701**

**Manheim, PA**  
4535 Elizabethtown Road  
Manheim, PA 17545-9410  
**717.664.0600**

**Watervliet, NY**  
958 19th Street  
Watervliet, NY 12189-1752  
**518.273.0801**

**Greensboro, NC**  
2700 Patterson Street  
Greensboro, NC 27407-2317  
**336.218.0801**

**Lebanon, PA**  
2225 Chestnut Street  
Lebanon, PA 17042-2504  
**717.664.0602**

**Friedens, PA**  
1510 Stoystown Road  
Friedens, PA 15541-7402  
**814.443.6800**

