



## storage tanks

### aboveground shelter tank

**HT-1001**

#### PRODUCT DETAILS

The Highland Shelter Tank is the most versatile solution for aboveground storage with complete containment.

This modular aboveground liquid storage system consists of a carbon steel or stainless steel storage tank housed within a 110% or 150% steel containment dike with shelter cover.

Shelter Tanks are ideal for the secure storage of petroleum, chemicals, hazardous wastes and fertilizers.

They are available in compartmented configurations for multiple product storage. Highland Shelter Tanks are easy to install.

Relocation, if necessary, is fast and easy. The entire tank system is product compatible and possesses the strength and impermeability of steel.

The Shelter Tank carries a UL-142 label and meets the NFPA 30 code. Highland Tank fabricates Shelter Tanks in a variety of standard sizes and can custom build to suit your specific needs.

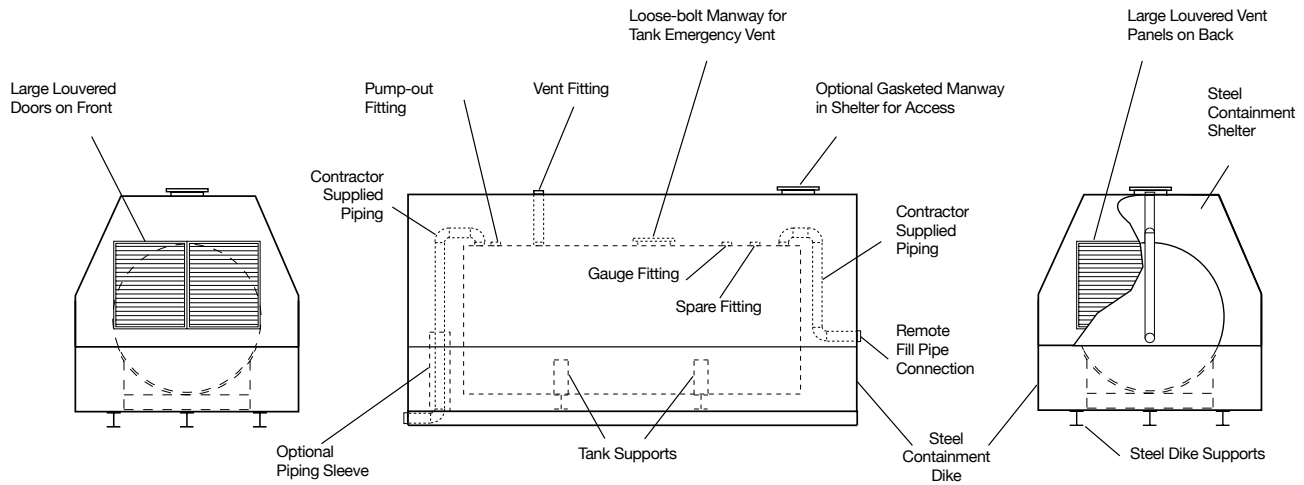

Volume Gallons	Tank Dimensions		Dike Dimensions		
	Diameter	Length	Length	Width	Height
240	3'-2"	3'-4"	4'-0"	5'-9"	1'-8"
300	3'-2"	4'-0"	7'-0"	4'-0"	1'-8"
500	4'-0"	5'-5"	7'-5"	6'-0"	1'-8"
1,000	4'-0"	10'-9"	12'-9"	6'-0"	2'-0"
1,000	5'-4"	6'-0"	9'-2"	8'-0"	2'-0"
1,500	5'-4"	9'-0"	13'-10"	8'-0"	2'-0"
2,000	5'-4"	12'-0"	16'-0"	8'-0"	2'-4"
2,500	5'-4"	15'-0"	17'-6"	8'-0"	2'-10"
3,000	5'-4"	18'-0"	22'-0"	8'-0"	2'-8"
4,000	5'-4"	24'-0"	28'-0"	8'-0"	2'-8"
5,000	8'-0"	13'-4"	17'-0"	10'-10"	4'-0"
6,000	8'-0"	16'-0"	20'-6"	10'-10"	4'-0"
8,000	8'-0"	21'-4"	27'-6"	10'-10"	4'-0"
10,000	8'-0"	26'-8"	35'-0"	10'-10"	4'-0"
12,000	8'-0"	32'-0"	36'-8"	12'-0"	4'-0"
15,000	10'-0"	25'-6"	31'-0"	12'-0"	6'-0"
20,000	10'-0"	34'-0"	41'-0"	12'-0"	6'-0"
25,000	10'-0"	42'-6"	51'-0"	12'-0"	6'-0"
30,000	10'-0"	51'-2"	61'-4"	12'-0"	6'-0"

A wide variety of options and accessories are also available to further customize a Shelter Tank to your requirements. Some of the items available include:

- Compartment bulkhead
- Tank insulation
- Manway with bolted and gasketed lid
- Dike piping sleeve
- Emergency vent
- External ladder/stairway
- Pump platform
- Platform/walkway with handrails
- Finish paint
- Internal ladder(s)
- Internal coating
- Level sensing/gauging system
- Overfill/spill containment chamber

Dike dimensions shown are for 110% containment dikes. Contact Highland Tank for details on 150% containment dikes. Overall height is dependent on shelter enclosure configuration.



**Stoystown, PA**  
One Highland Road  
Stoystown, PA 15563-0338  
**814.893.5701**

**Manheim, PA**  
4535 Elizabethtown Road  
Manheim, PA 17545-9410  
**717.664.0600**

**Watervliet, NY**  
958 19th Street  
Watervliet, NY 12189-1752  
**518.273.0801**

**Greensboro, NC**  
2700 Patterson Street  
Greensboro, NC 27407-2317  
**336.218.0801**

**Lebanon, PA**  
2225 Chestnut Street  
Lebanon, PA 17042-2504  
**717.664.0602**

**Friedens, PA**  
1510 Stoystown Road  
Friedens, PA 15541-7402  
**814.443.6800**



PROUDLY MADE IN AMERICA