

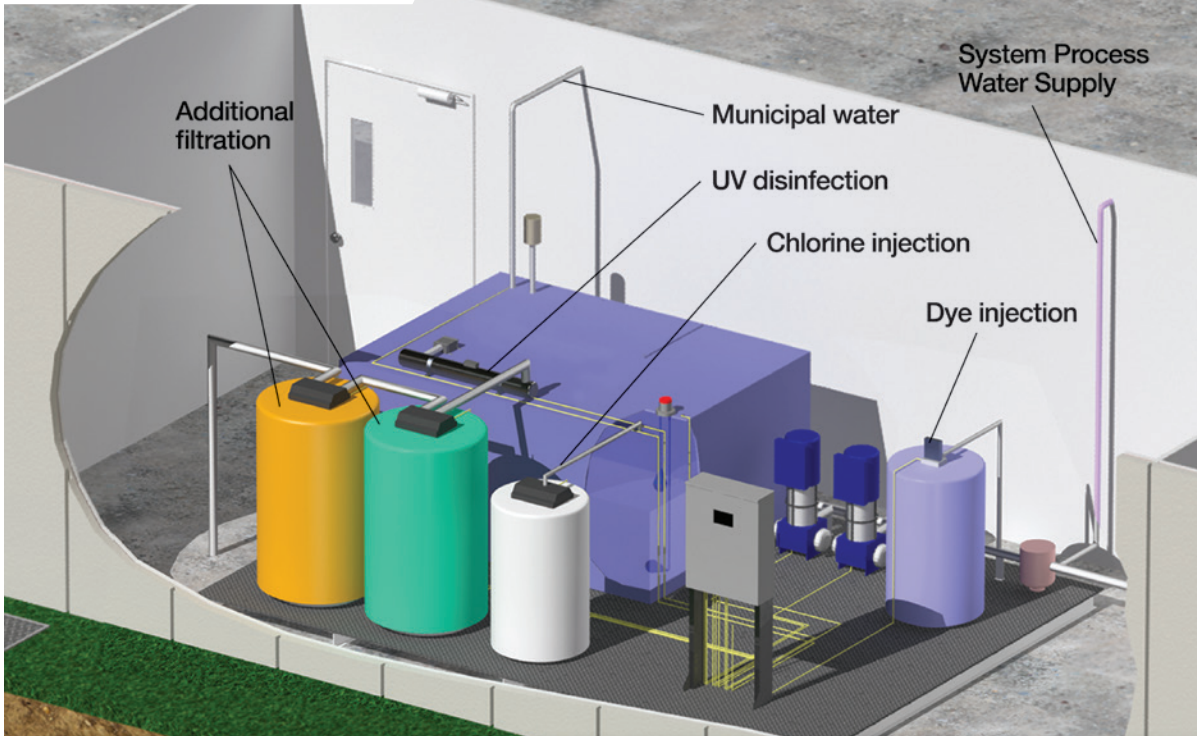

Monitor water quality and make-up

- Tank levels (Day & Cistern)
- Pump performance & pressure
- Filter performance



rainwater harvesting management

HT-6107

High-LINK® Integrated Systems couple superior steel tank products with state-of-the-art electronic management devices and SCI's proprietary software providing real-time data to optimize usage and transfer of **any liquid operation.**

Water is a complex medium. Without it, the ecology of earth could not function. Water quality parameters are relative to its intended use. Water for human consumption will inherently have a different standard to meet than water used in industrial/commercial applications.

In either case, Highland Tank provides monitoring to measure the physical, chemical, and biological constituents in any given waste stream to ensure compliance.

Elements in water like microorganisms, dissolved minerals, hydrocarbons, and grease are all regulated by the EPA Clean Water Act and/or FDA with strict limits on discharge to the environment.

Highland Tank can provide real time condition monitoring and management of pH, TDS, alkalinity, chlorine, temperature and more to validate quality and ensure water compliance.

High-LINK®'s powerful software records data obtained from real time, on-site measurements compiling meaningful patterns so we can make informed decisions based on data.

High-LINK® uses benchmarks to predict and improve both efficiency and performance of the HighDRO®-Pure Rainwater Harvesting System.

Our water is the most precious resource and must be maintained for future generations.

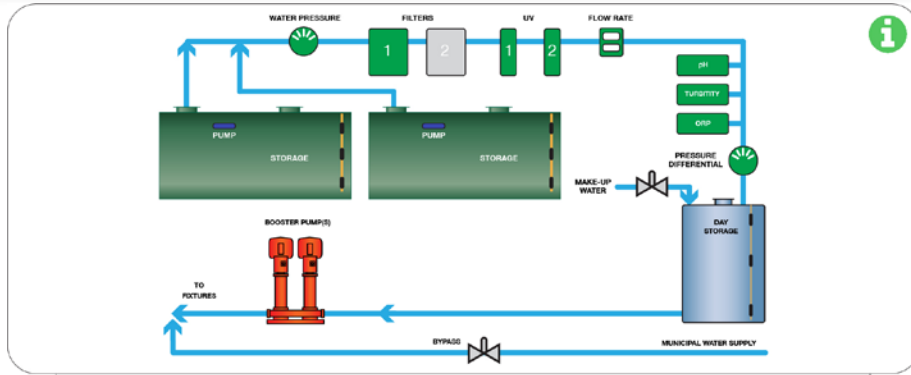

The above images show the front of the control panel with touchscreen and the inside components of the panel.

HighDRO® Water System		ID: BB-Bldg-12
WATER PRESSURE: _____	RCT - 1	BOOSTER PUMP(S)
FILTER 1: _____	PUMP 1 CURRENT: _____	RPM: _____
FILTER 2: _____	CAPACITY: _____	POWER: _____
UV 1: _____	NOMINAL SIZE: _____	PSI SET: _____
UV 2: _____	HEIGHT (IN): _____	FREQUENCY: _____
FLOW RATE: _____ GPM	LEVEL: _____	CURRENT: _____
TOTAL FLOW: _____ GAL	RCT - 2	FAULTS: _____
PH: _____	PUMP 1 CURRENT: _____	TORQUE: _____
TURBIDITY: _____	CAPACITY: _____	PRESSURE: _____
ORP: _____	NOMINAL SIZE: _____	
DIFFERENTIAL PRESSURE: _____	HEIGHT (IN): _____	MAKE UP WATER: ON / OFF
DAY TANK LEVEL: _____	LEVEL: _____	BYPASS VALVE: OPEN / CLOSED

- Features:**
- Measure processed water, levels in chlorine, dye, cistern(s), and day tank, pump performance, pressure, UV intensity, water quality, and much more
 - Predictive maintenance techniques applied as "best practice" elevates efficiency, reduces operating costs, and provides a level of service never seen in the steel tank industry
 - 5-Year bumper-to-bumper warranty with purchase of monitoring contract
 - Start-up inspection, troubleshooting, on-site service available

PRODUCT DETAILS

High-LINK® uses advanced monitoring hardware and software to manage rainwater harvesting systems by providing access to the entire system from any smart phone, tablet, or computer.

High-LINK® adds value

- Extends the standard warranty and qualifying your building for LEED Green Building points.
- Allows Highland Tank to provide better service for your system
- Minimizes down-time encountered for maintenance and other service.

All equipment must be installed in accordance with manufacturers, local, state, and national plumbing codes and standards.

*Water Chemistry & Quality Disclaimer
Highland Tank does not warranty water chemistry that exceeds the numerical values of the associated filtration and disinfection equipment. These values include Turbidity (>10 NTU), Particulate Matter (see specified filtration micron value), pH (<6->8), or Disinfection (<500 CFU/100 ml).*

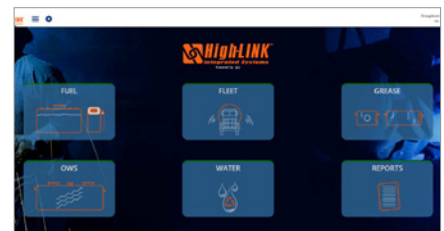

High-LINK® user interface dashboard.



Highland Tank®

Stoystown, PA
One Highland Road
Stoystown, PA 15563-0338
814.893.5701

Manheim, PA
4535 Elizabethtown Road
Manheim, PA 17545-9410
717.664.0600

Watervliet, NY
958 19th Street
Watervliet, NY 12189-1752
518.273.0801

Greensboro, NC
2700 Patterson Street
Greensboro, NC 27407-2317
336.218.0801

Lebanon, PA
2225 Chestnut Street
Lebanon, PA 17042-2504
717.664.0602

Friedens, PA
1510 Stoystown Road
Friedens, PA 15541-7402
814.443.6800

Clarkston, MI
4701 White Lake Road
Clarkston, MI 48346-2554
248.625.8700

Mancelona, MI
9517 Lake Street
Mancelona, MI 49659-7968
231.587.8412



PROUDLY MADE IN AMERICA