

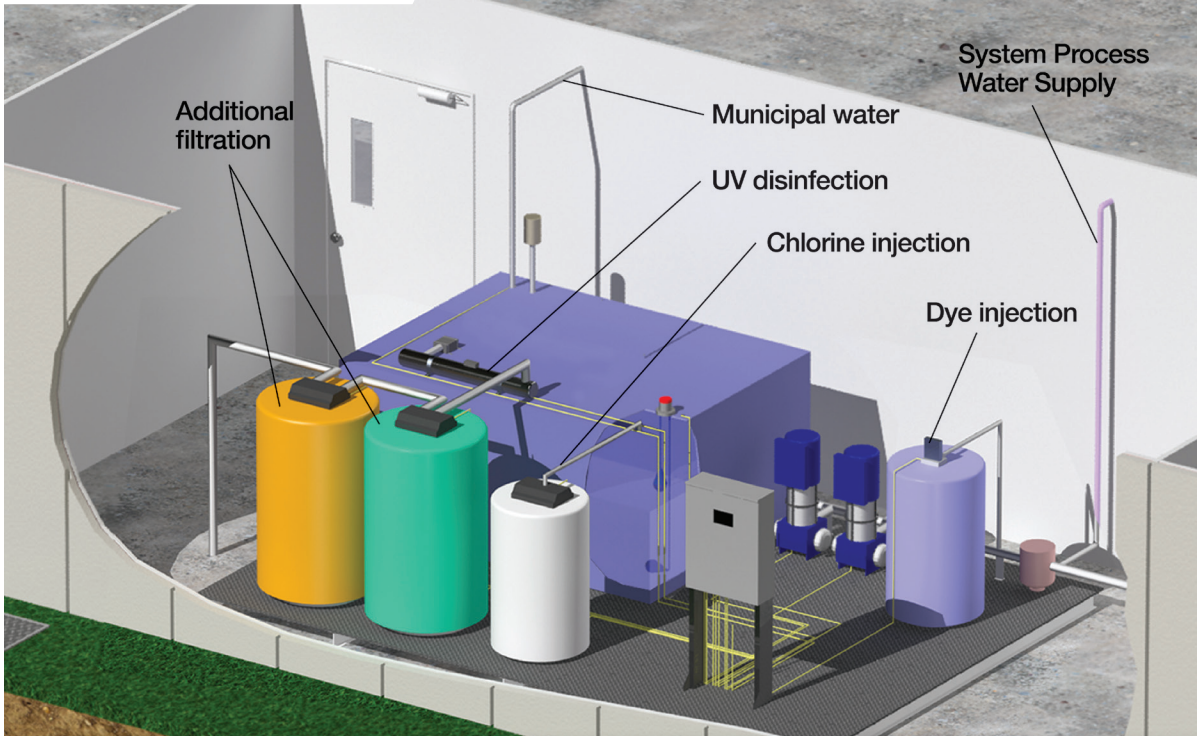

Monitor water quality and make-up

- Tank levels (Day & Cistern)
- Pump performance & pressure
- Filter performance



rainwater harvesting management

HT-6107

High-LINK® Integrated Systems couple superior steel tank products with state-of-the-art electronic management devices and SCI's proprietary software providing real-time data to optimize usage and transfer of **any liquid operation.**

Water is a complex medium. Without it, the ecology of earth could not function. Water quality parameters are relative to its intended use. Water for human consumption will inherently have a different standard to meet than water used in industrial/commercial applications.

In either case, Highland Tank provides monitoring to measure the physical, chemical, and biological constituents in any given waste stream to ensure compliance.

Elements in water like microorganisms, dissolved minerals, hydrocarbons, and grease are all regulated by the EPA Clean Water Act and/or FDA with strict limits on discharge to the environment.

Highland Tank can provide real time condition monitoring and management of pH, TDS, alkalinity, chlorine, temperature and more to validate quality and ensure water compliance.

High-LINK's powerful software records data obtained from real time, on-site measurements compiling meaningful patterns so we can make informed decisions based on data.

High-LINK uses benchmarks to predict and improve both efficiency and performance of the HighDRO®-Pure Rainwater Harvesting System.

Our water is the most precious resource and must be maintained for future generations.

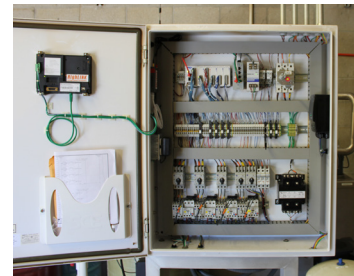
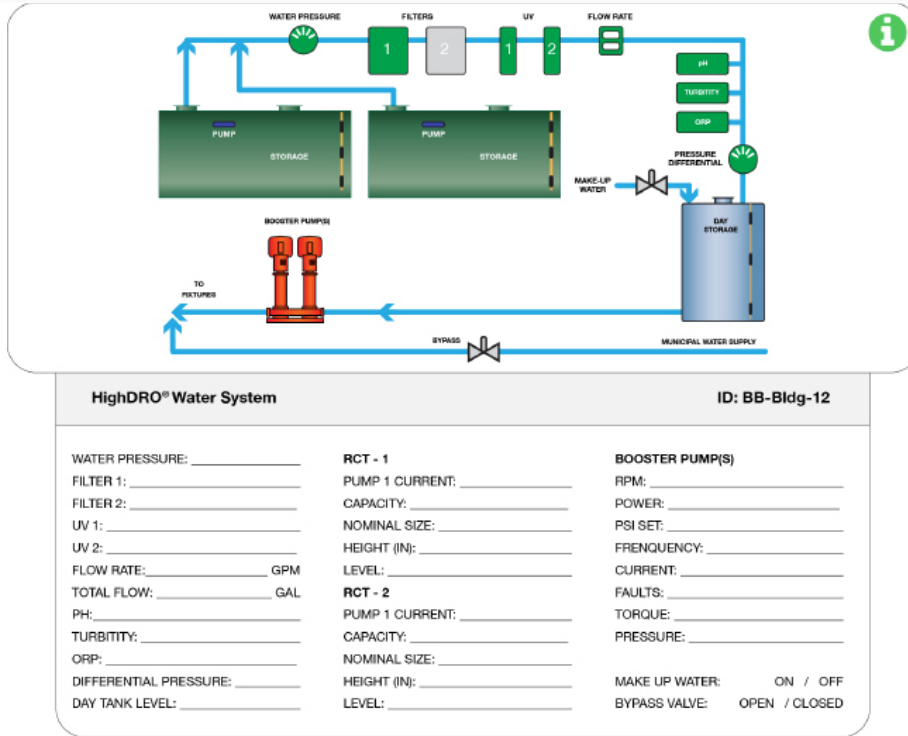

The above images show the front of the control panel with touchscreen and the inside components of the panel.

- Features:**
- Measure processed water, levels in chlorine, dye, cistern(s), and day tank, pump performance, pressure, UV intensity, water quality, and much more
  - Predictive maintenance techniques applied as "best practice" elevates efficiency, reduces operating costs, and provides a level of service never seen in the steel tank industry
  - 5-Year bumper-to-bumper warranty with purchase of monitoring contract
  - Start-up inspection, troubleshooting, on-site service available

**PRODUCT DETAILS**

High-LINK® uses advanced monitoring hardware and software to manage rainwater harvesting systems by providing access to the entire system from any smart phone, tablet, or computer.

High-LINK® adds value

- Extends the standard warranty and qualifying your building for LEED Green Building points.
- Allows Highland Tank to provide better service for your system
- Minimizes down-time encountered for maintenance and other service.

All equipment must be installed in accordance with manufacturers, local, state, and national plumbing codes and standards.

**Water Chemistry & Quality Disclaimer**  
 Highland Tank does not warranty water chemistry that exceeds the numerical values of the associated filtration and disinfection equipment. These values include Turbidity (>10 NTU), Particulate Matter (see specified filtration micron value), pH (<6->8), or Disinfection (<500 CFU/100 ml).

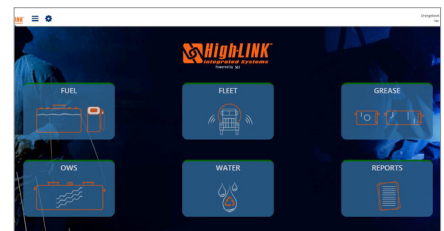

High-LINK® user interface dashboard.



**Stoystown, PA**  
 One Highland Road  
 Stoystown, PA 15563-0338  
**814.893.5701**

**Manheim, PA**  
 4535 Elizabethtown Road  
 Manheim, PA 17545-9410  
**717.664.0600**

**Watervliet, NY**  
 958 19th Street  
 Watervliet, NY 12189-1752  
**518.273.0801**

**Greensboro, NC**  
 2700 Patterson Street  
 Greensboro, NC 27407-2317  
**336.218.0801**

**Friedens, PA**  
 1510 Stoystown Road  
 Friedens, PA 15541-7402  
**814.443.6800**

**Clarkston, MI**  
 4701 White Lake Road  
 Clarkston, MI 48346-2554  
**248.625.8700**

**Mancelona, MI**  
 9517 Lake Street  
 Mancelona, MI 49659-7968  
**231.587.8412**



**PROUDLY MADE IN AMERICA**